

System Summary

The PRO-10 Twin System provides excellent sediment filtration, chlorine removal and mineral scale control for water-fed equipment such as ice machines.

The system utilizes a premium high grade carbon block filter ensuring high flow rates and treatment volumes.

The PRO-10 Twin System also incorporates the patented HydroBlend™/ScaleStick™ scale control insert providing unparalleled mineral scale prevention and corrosion control for predictable treatment periods.



Benefits

Mineral scale buildup responsible for increased maintenance is reduced

Removes sediment that causes cloudy ice and plugs distribution tubes and float valves

Energy efficiency and machine life are increased while reducing costly service calls

Removes chlorine to improve taste and reduce potential corrosion issues

Features

Bayonet style quick disconnect cartridge makes filter replacement sanitary, quick and easy

Compact design facilitates system placement and installation

HydroBlend™/ScaleStick™ insert provides optimum scale prevention and a consistent feed throughout the life of the cartridge

NSF Certified under Standard 42

Installation Summary

Place system in an accessible location for ease of filter replacement

Ensure that the system is mounted vertically with a minimum of 2" clearance from the bottom of the system to allow for filter replacement

Cold water inlet feed only

Do not over tighten fittings

Operating Tips

Recommended cartridge replacement every 6 months

Application

Ice Machines

System Specifications

Rated Service Flow

3.3 gpm. (12.49 lpm.)

Rated Capacity

20,000 gal. (Chlorine Removal)

Operating Pressure

30 - 125 psi. (2 - 8.6 bar) non-shock

Operating Temperature

35° - 100°F (2° - 38°C)

Connection Size

1/2" MNPT

Shipping Weight

6 lbs.

System Dimensions

15.25" x 13" x 4" (HxWxD)

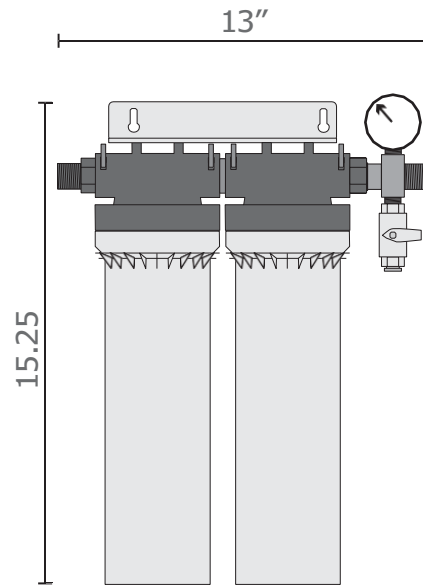

Replacement Filter(s)

(2) PRO-10 Cartridge

Warranty

PRO systems are covered by a limited warranty against defects in material or workmanship for a period of 1 year after the date of purchase.

PRO replacement filters are covered by a limited warranty against defects in material or workmanship for a period of 1 year after the date of purchase.

Please call (407) 826-1861 for further warranty information.

Additional Info

Do not use with water that is microbiologically unsafe or unknown quality without adequate disinfection before or after the system

System should be installed in compliance with state and local laws and regulations.