



DESPIECE / REPUESTOS
EXPLODED VIEW / SPARE PARTS
EXPLOSIONSZEICHNUNG / ERSATZTEILE
VUE ÉCLATÉÉ / PIÈCES DÉTACHÉES
ESPLOSO / RICAMBI

AIR CONDENSER UNIT



FD/HD 215 (30")

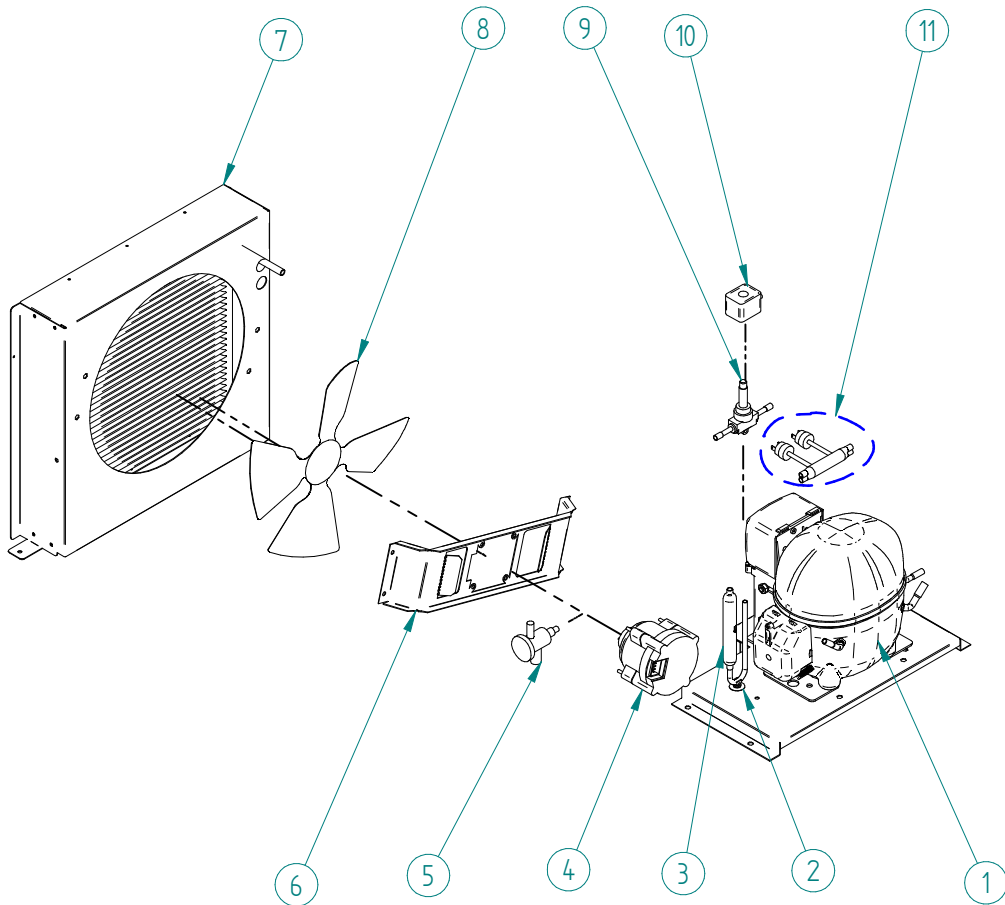

ITEM	DESCRIPTION	30"	
			215
1	COMPRESSOR	220V/50HZ	31307
		220V/60HZ	32762
		115V/60HZ	33423
2	PLASTIC CLIP 1/4"		3533
3	DRIER FILTER		7896
4	FAN MOTOR	220V/50-60HZ	35515
		115V/60HZ	35515
5	EXPANSION VALVE		31524
6	FAN SUPPORT		6500U
7	AIR CONDENSER		32156
8	FAN BLADE	220V/50-60HZ	6398
		115V/60HZ	35173
9	HOT GAS VALVE - BODY		6396
10	HOT GAS VALVE - COIL	220V/50-60HZ	5173
		115V/60HZ	5414
11	PRESSURE SWITCHES		32695K

WATER CONDENSER UNIT



FD/HD 215 (30")

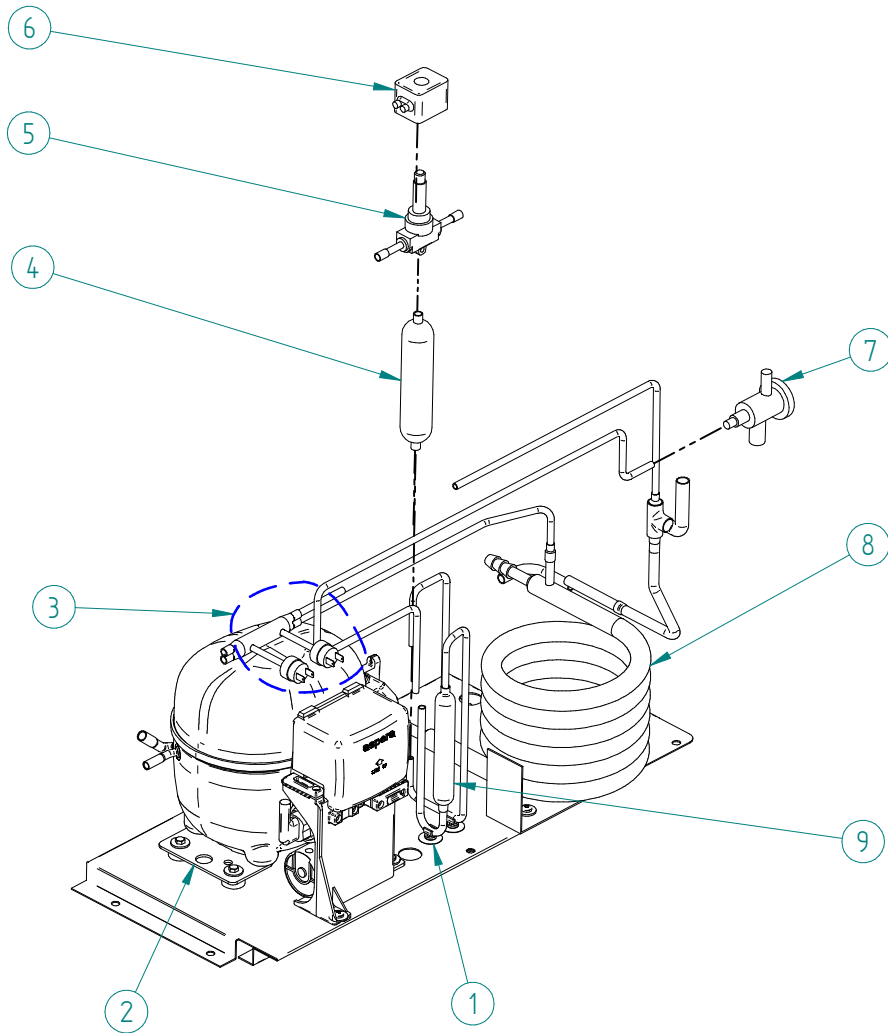

ITEM	DESCRIPTION	30"
		215
1	PLASTIC CLIP 1/4"	3533
2	COMPRESSOR	220V/50HZ 31307
		115V/60HZ 33423
3	PRESSURE SWITCHES	32695K
4	SEP PARTICLES	1570
5	HOT GAS VALVE - BODY	6396
6	HOT GAS VALVE - COIL	220V/50HZ 5173
		115V/60HZ 5414
7	EXPANSION VALVE	31524
8	CONDENSATOR	33671
9	DRIER FILTER	7896

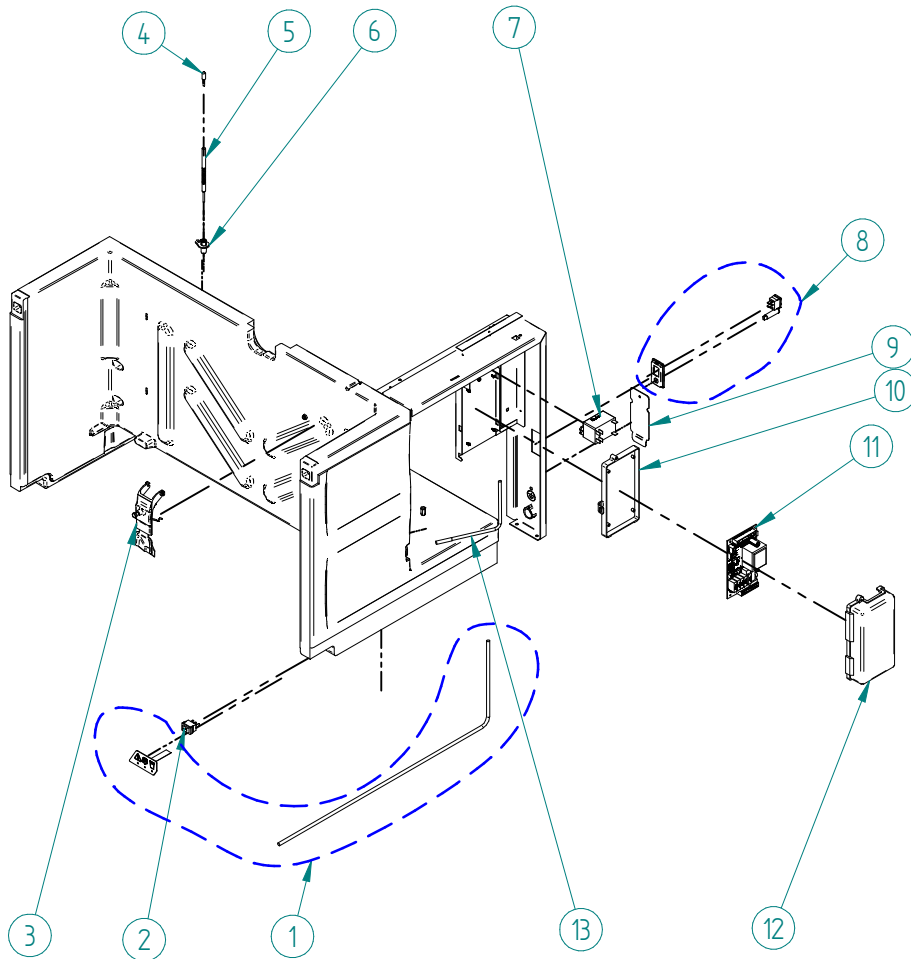

ITEM	DESCRIPTION	30"	
		215	
1	DISPLAY MS	220V/50-60HZ 115V/60HZ	34577K N/A
2	SWITCH (ICE-STANDBY-WASH)		6161
3	THICKNESS ICE BLOCK SENSOR		6334B
4	COMPRESSION RING		504
5	ISOLATED WATER LEVEL SENSOR		30982
6	SUPPORT WATER LEVEL SENSOR		8670
7	RELAY	220V/50-60HZ 115V/60HZ	32502 32501
8	MAIN SWITCH		32416K
9	JUNCTION BOX COVER	220V/50-60HZ 115V/60HZ	N/A 31921
10	ELECTRIC BOX		2181
11	ELECTRONIC BOARD	220V/50-60HZ 115V/60HZ	34642 6253D
12	ELECTRIC BOX COVER		30861
13	SENSOR		6521A

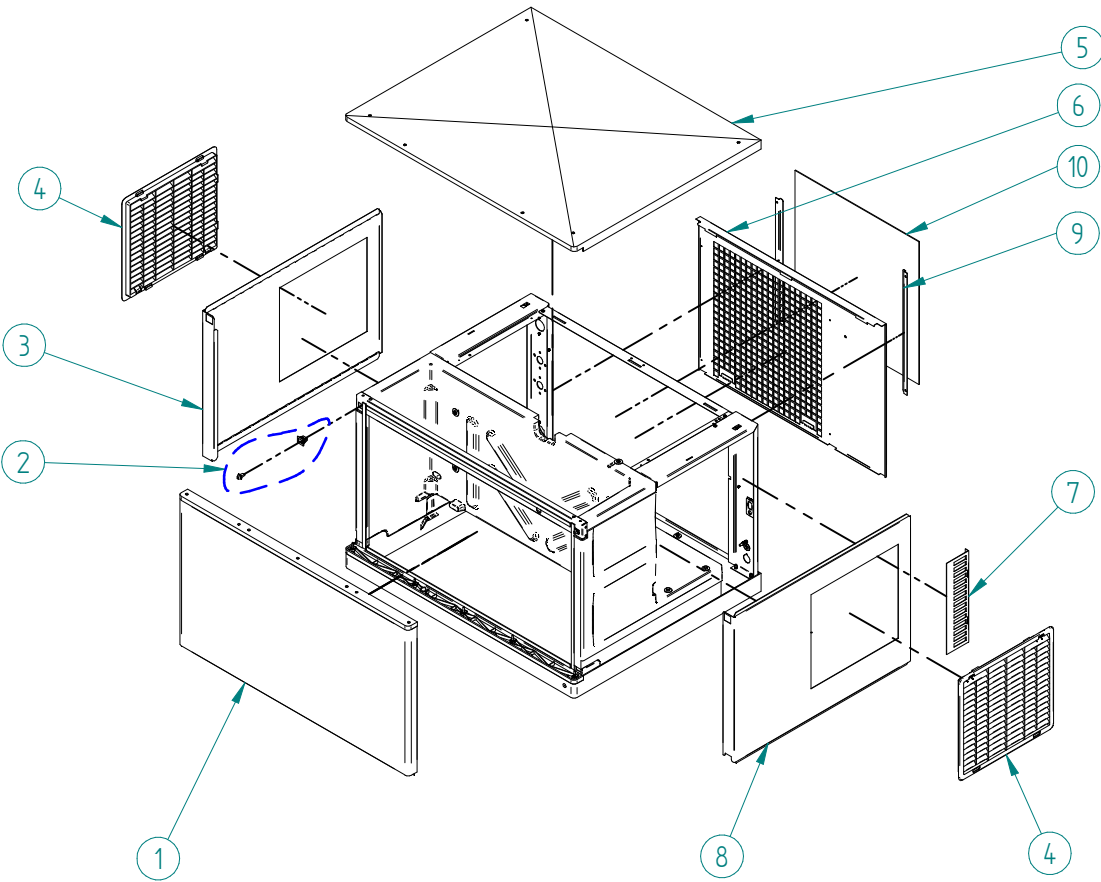

ITEM	DESCRIPTION	30"
		215
1	FRONT PANEL	6269
2	PANEL CLIP	6181K
3	LEFT PANEL	6328
4	SIDE LOUVER	6084
5	TOP PANEL	6073
6	REAR PANEL	6315U
7	WIRE PROTECTION GRILL	32835
8	RIGHT PANEL	6327
9	AIR FILTER GUIDE	35332
10	AIR FILTER	35452A

HYDRAULIC PARTS



FD/HD 215 (30")

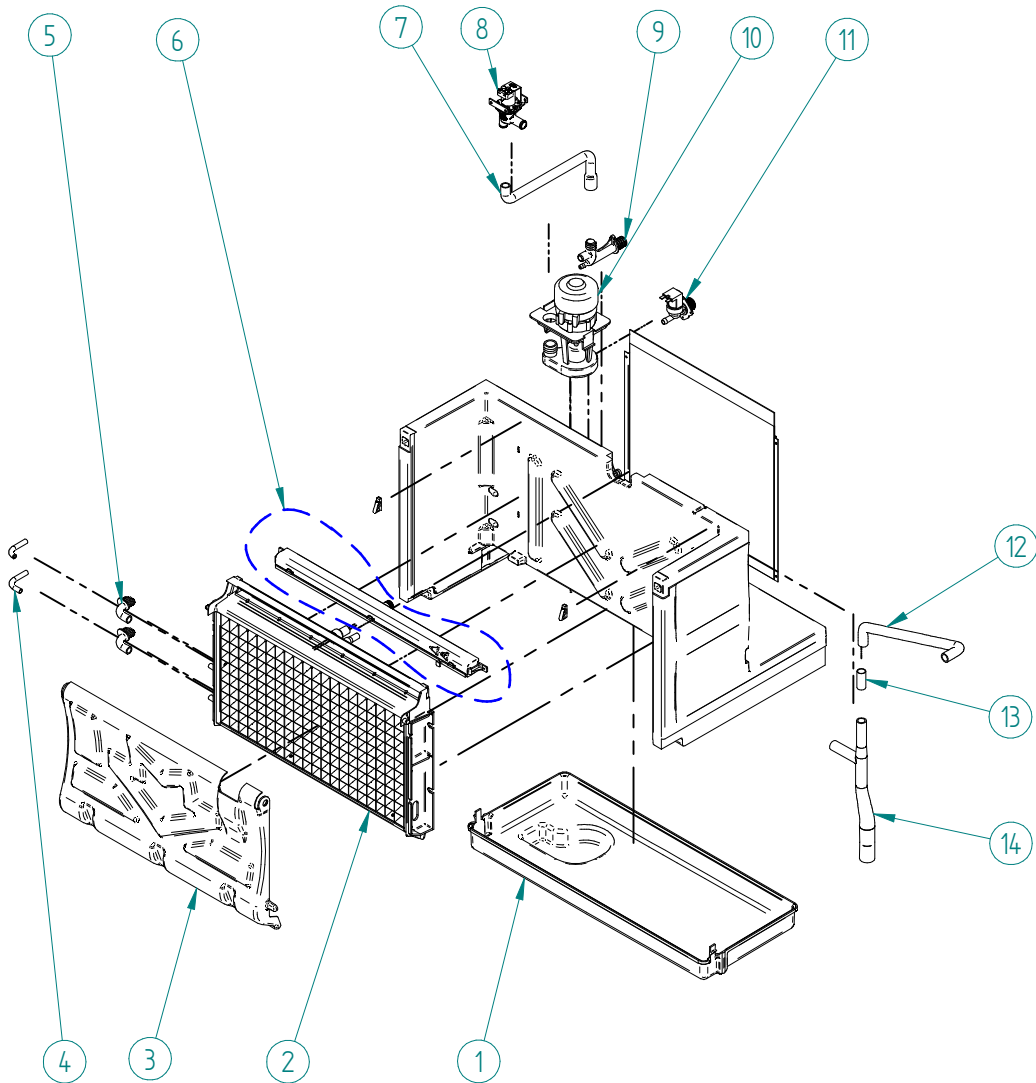

ITEM	DESCRIPTION	30"
		215
1	WATER BIN	6078
2	EVAPORATOR FULL DICE ASSY	6337A
	EVAPORATOR HALF DICE ASSY	6338A
3	CURTAIN	6081K
4	PIPE	3363
5	PIPE PROTECTION	6132
6	WATER DISTRIBUTOR	Ø7 Restrictor 30039G
		Ø9 Restrictor 6485G
7	DRAIN TUBE	6131
8	WATER DRAIN VALVE	220V/50-60HZ 6183
		115V/60HZ 6182
9	DRAIN FITTING	6206
10	WATER PUMP	220V/50-60HZ 6509
		115V/60HZ 6508
11	INLET WATER VALVE	220V/50-60HZ 7688
		115V/60HZ 6984
12	UPPER WATER PUMP DISCHARGE TUBE	6129A
13	WATER PUMP DISCHARGE TUBES JUNCTION	6526
14	LOWER WATER PUMP DISCHARGE TUBE	6130A