

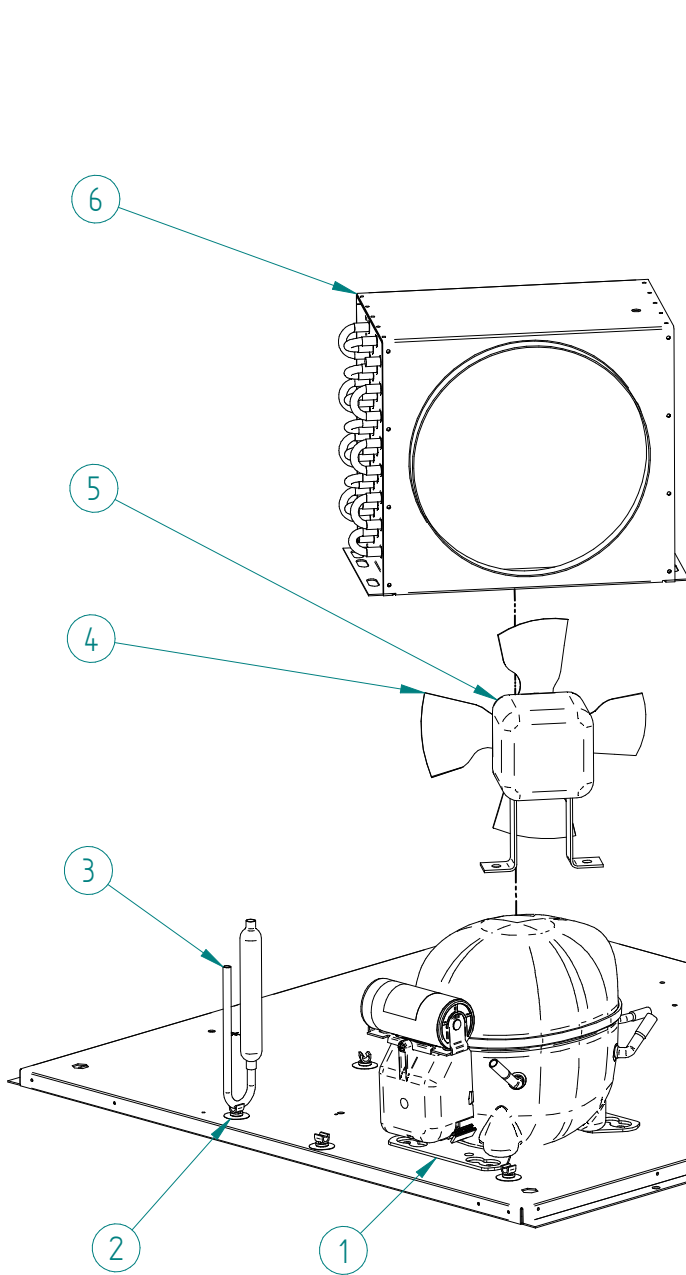

DESPIECE / REPUESTOS
EXPLODED VIEW / SPARE PARTS
EXPLOSIONSZEICHNUNG / ERSATZTEILE
VUE ÉCLATÉÉ / PIÈCES DÉTACHÉES
ESPLOSO / RICAMBI

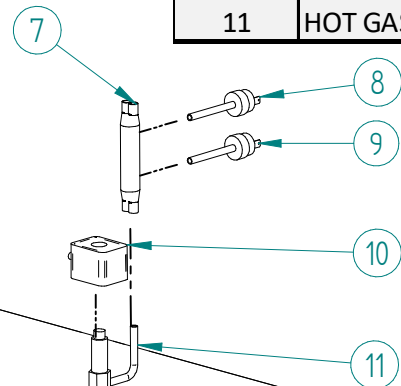

ITEM	DESCRIPTION	FDHD R290				
		50	70	100	150	
1	COMPRESSOR	220V/50HZ	31300	31302	31303	31306
		220V/60HZ		N/A		32761
		115V/60HZ	31450	31451	31452	31454
2	PLASTIC CLIP 1/4"		3533			
3	FILTER DRIER		7896			
4	FAN BLADE		4887			
5	FAN MOTOR	220V/50-60HZ	28			
		115V/60HZ	4890			
6	AIR CONDENSER		486	487	32251	
7	PRESSURE SWITCH COLLECTOR		31444			
8	FAN CONTROL PRESSURE SWITCH		31160E			
9	HIGH PRESSURE SWITCH		31660E			
10	HOT GAS VALVE - COIL	220V/50-60HZ	5173			
		115V/60HZ	5414			
11	HOT GAS VALVE - BODY		1468		1473	



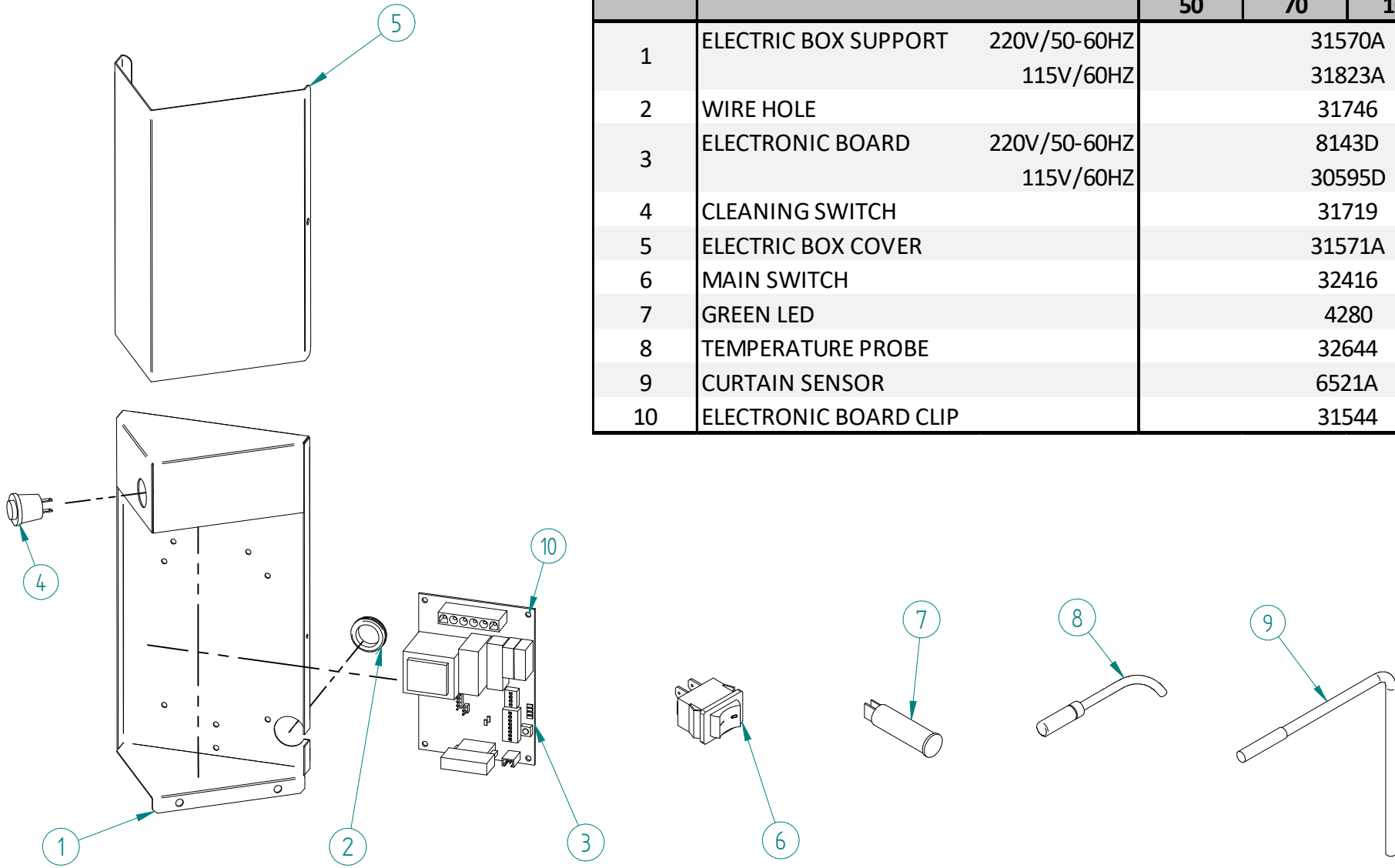

ITEM	DESCRIPTION	FDHD R290			
		50	70	100	150
1	ELECTRIC BOX SUPPORT 220V/50-60HZ 115V/60HZ		31570A		
2	WIRE HOLE		31746		
3	ELECTRONIC BOARD 220V/50-60HZ 115V/60HZ		8143D		
4	CLEANING SWITCH		31719		
5	ELECTRIC BOX COVER		31571A		
6	MAIN SWITCH		32416		
7	GREEN LED		4280		
8	TEMPERATURE PROBE		32644		
9	CURTAIN SENSOR		6521A		
10	ELECTRONIC BOARD CLIP		31544		

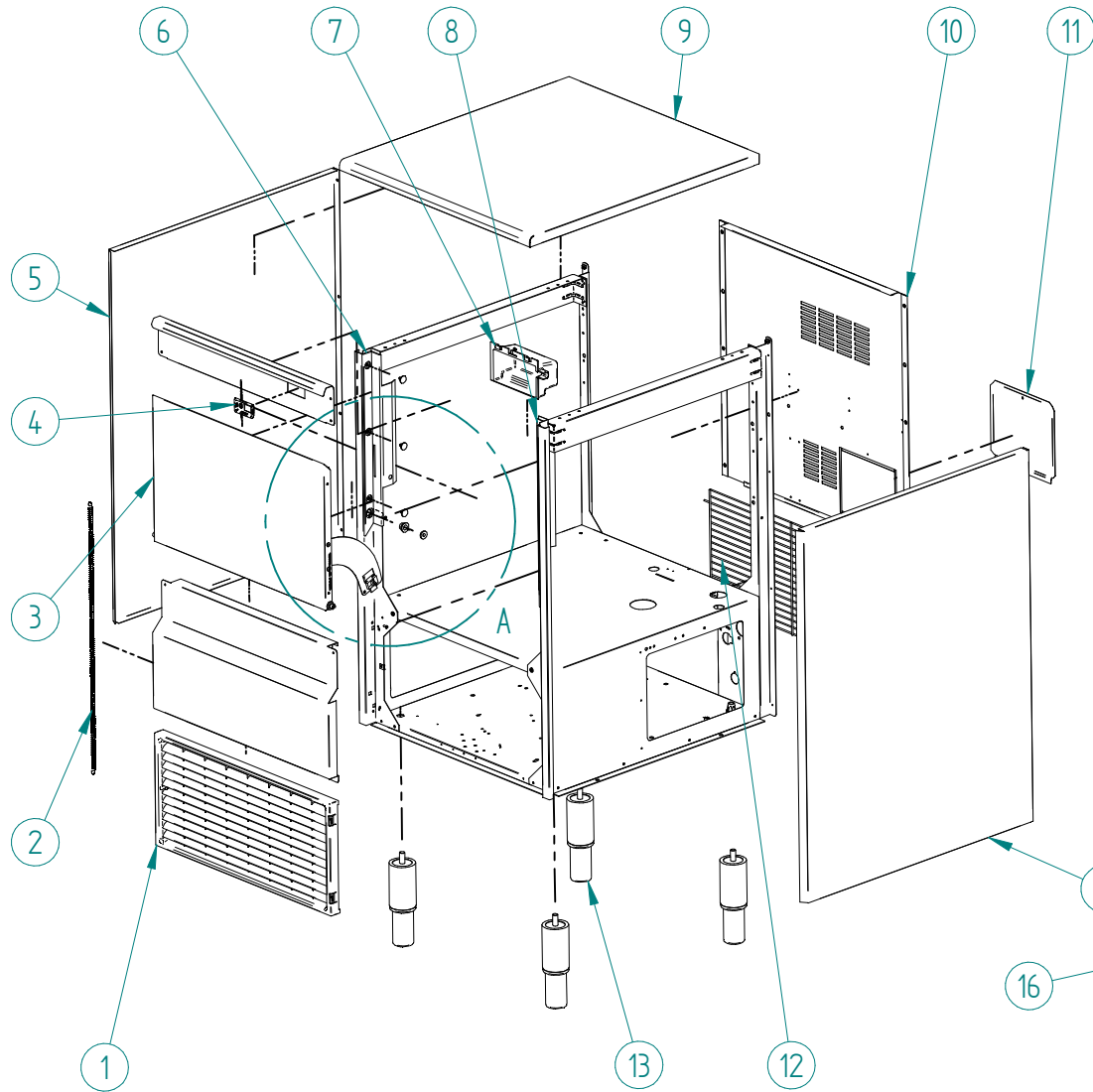

ITEM	DESCRIPTION	FDHD R290			
		50	70	100	150
1	FRONT LOUVER	4393		8699	8700
2	DOOR SPRING		702		
3	DOOR ASSEMBLY	5791		6295	6296
4	MAIN SWITCH SUPPORT		32441		
5A	RIGHT PANEL			6285	6287
5B	LEFT PANEL	489UA		6286	6288
6	LEFT DOOR GUARD		83		
7	MAIN SWITCH BOX		31665		
8	RIGHT DOOR GUARD		82		
9	TOP PANEL	4170A		6283A	6284A
10	REAR COVER	4172A		6300	6301
11	COVER PUMP		6306		
12	REAR GRILL	4088		6209	2192
13	LEG		1478		
14	DOOR AXE BEARING		1001		
15	DOOR AXE BUSHING		155		
16	CLIP		113		
17	DOOR BUMPER		156		
18	DOOR SCREW		392		

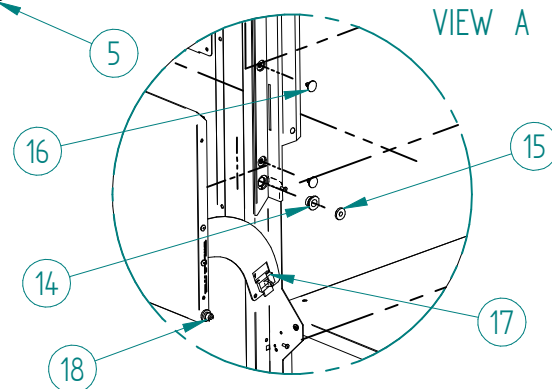

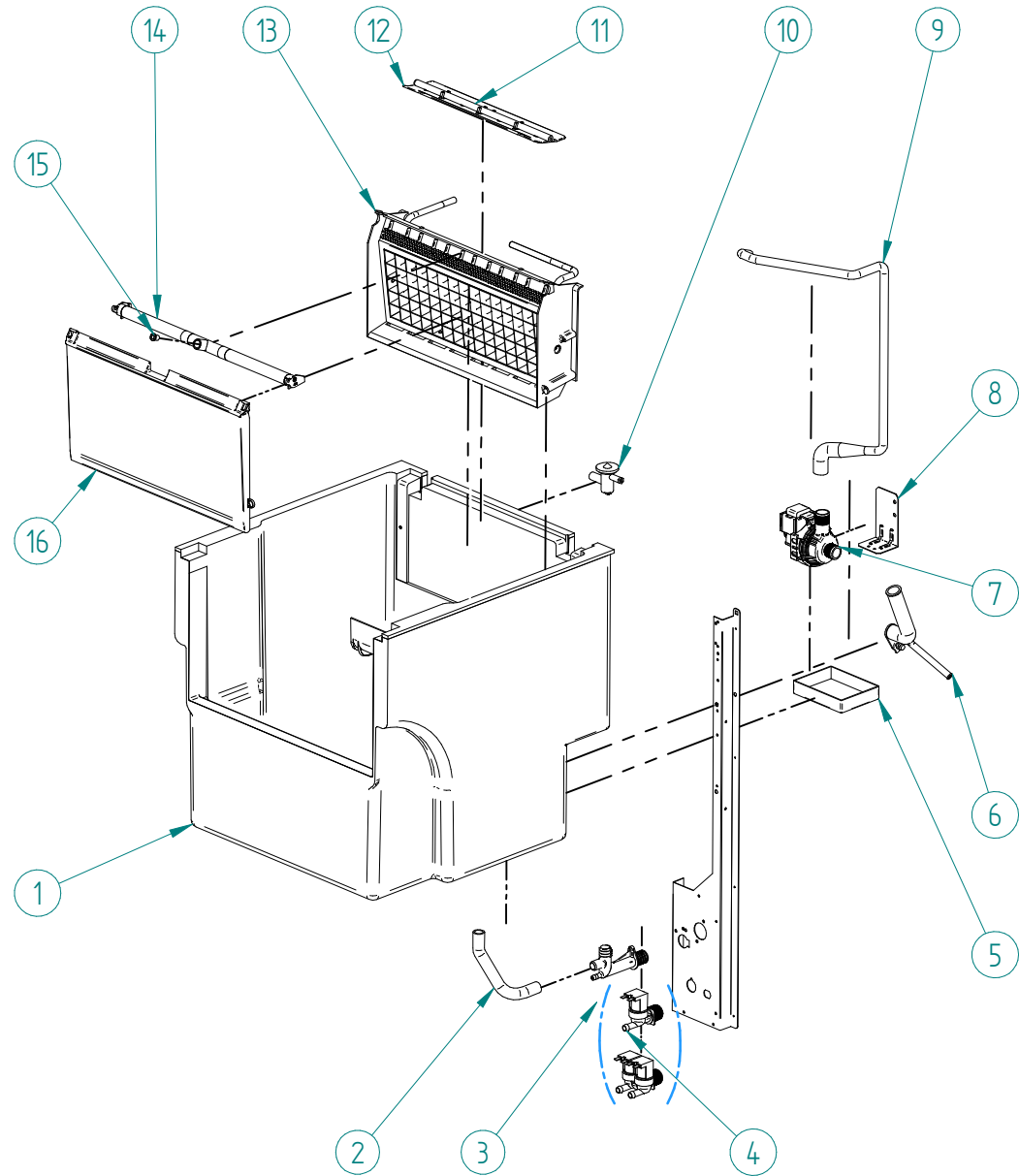

ITEM	DESCRIPTION	FDHD R290			
		50	70	100	150
1	BIN	6245U		6246U	6247A
2	DRAIN TUBE		2222		
3	DRAIN FITTING		363		
4	INLET WATER VALVE	220V/50HZ		329	
		220V/60HZ		N/A	4897
		115V/60HZ		2783	
5	WATER PUMP TRAY		4521		
6	WATER PUMP SUCTION TUBE		4961		
7	WATER PUMP	220V/50HZ		4769	
		115-220V/60HZ		31982	
8	PUMP SUPPORT	220V/50HZ		4956	
		115-220V/60HZ		32022	
9	WATER PUMP DISCHARGE TUBE	6126		6128	
10	EXPANSION VALVE	31521		31523	31524
11	WATER INLET TUBE	6462		N/A	
12	WATER INLET SUPPORT	6099		N/A	
13	EVAPORATOR FULL DICE ASSY		6224	6230	6236
			6227	6233	6239
14	FRONT WATER DISTRIBUTOR	30041A		30039	30040
15	WATER FLOW RESTRICTOR	220V/50HZ	6403	6414	6485
		115-220V/60HZ	32006	32007	32008
16	CURTAIN	6095B		6093A	6094A

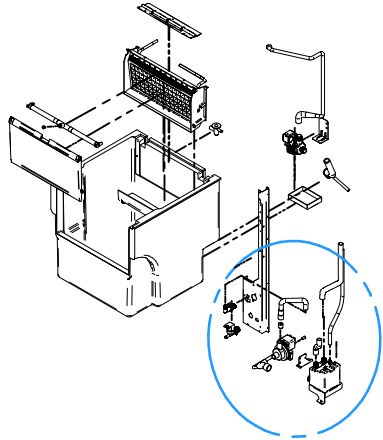

ITEM	DESCRIPTION	FDHD R290			
		50	70	100	150
1	PUMP OUT DRAIN FORCE TUBE	32457			
2	DRAIN FORCE TUBE DISCHARGE WATER BIN	32453			
3	VENT TUBE	1719			
4	PLUG	614			
5	DRAIN FORCE TUBE DISCHARGE BIN	32456			
6	DRAIN FORCE BUCKET SET	32571		32625	
7	DRAIN FORCE PUMP SUPPORT	32573		32786	
8	DRAIN FORCE PUMP SUCTION TUBE	32455			
9	DRAIN FORCE PUMP	220V/50Hz		32624	
		220V/60Hz		32622	
		115V/60Hz		32623	
10	CHECK VALVE RX3/4	32451			
11	DRAIN FORCE FITTING	30850			

