

# **USER MANUAL**

# **MANUAL DEL UTILIZADOR**

ENGLISH

## **MODELS / MODELOS**

**50C-CD 55**

**85C-CD 90**

**135C-GR 140**

**150**

**200/175-GR 220**

**400/355**

**550/475-GR 560**

**G550-GR 560S**

**1100**

**G1100**

**USER MANUAL**  
**MANUAL DEL UTILIZADOR**

**THIS MANUAL IS PART OF THE PRODUCT. READ IT CAREFULLY IN ORDER TO USE AND MAINTAIN THE EQUIPMENT CORRECTLY. IT IS IMPORTANT TO KEEP IT FOR FUTURE TROUBLESHOOTING AND REFERENCE.**

## **WARNING**

---

The installation of this equipment should be done by the Technical Assistance Service department.

The inlet jack should always be placed on an accessible location.

ALWAYS disconnect the power supply from the machine BEFORE any cleaning or maintenance service.

Any change needed on the electrical installation for the appropriate connection of the machine, should be exclusively performed by qualified and certified professional personnel only.

Any use by the ice maker not intended to produce ice, using drinking water, is considered inappropriate.

It is extremely dangerous to modify or intend to modify this machine, and shall make any type warranty void.

This machine should not be used by children or handicapped without the proper supervision and monitoring.

Children should be monitored to assure that they should not play near the equipment.

This machine is not intended to be used outdoors nor exposed to the rain.

Connect the equipment to the drinking water network.

The machine should be connected using the power cable supplied with the equipment. The connection is not intended for fixed cabling.

### **IT IS MANDATORY TO GROUND THE EQUIPMENT.**

**To avoid possible discharges on individuals or damages to the equipment, the machine should be grounded pursuant local and/or national regulations as the case may be.**

**THE MANUFACTURER SHALL BE HELD HARMLESS IN CASE OF DAMAGES ARISING DUE TO THE LACK OF THE GROUND INSTALLATION.**

In order to assure the proper operation and efficiency of this equipment, it is of paramount importance to follow the recommendations of the manufacturer, SPECIALLY THOSE RELATED TO CLEANING AND MAINTENANCE OPERATIONS, which should be performed mostly by qualified personnel only.

### **CAUTION:**

Do not try to perform repairs. The intervention of non-qualified personnel, besides of being dangerous, could result in serious malfunctioning. In case of damages, contact your distributor. We recommend to always use original replacement and spare parts.

Perform all discharge and recovery of materials or waste according the national regulations in force.

## RECEPTION OF THE MACHINE

Inspect the outside packing. In case of damages, MAKE THE CORRESPONDING CLAIM TO THE CARRIER.

To confirm the existence of damages, UNPACK THE MACHINE IN THE PRESENCE OF THE CARRIER and state any damage on the equipment on the reception document, or on a separate instrument. As from May 1, 1998, we comply with the European regulations on management of packing and packing waste, inserting the “**Green Dot Label**” on all their packages.

Always state the machine number and model. This number is printed on four locations:

### 1. PACKING

On the outside, it contains a label with the manufacturing number (I).

### 2. EXTERIOR OF THE EQUIPMENT

On the back of the equipment, there appears a label with the same characteristics as the previous one (I).

### 3. NAMEPLATE

On the back of the machine.

Check that in interior of the machine the installation kit is complete and comprises:

- Ice scraper,  $\frac{3}{4}$  gas pipe, filters and manual.
- 22 mm drain hose in models 45 and 85 and in water cooled machines
- In some models, shims are included.
- Warranty and serial number.

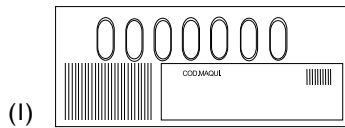
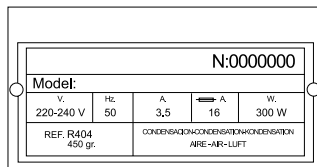

**CAUTION: ALL PACKING ELEMENTS (plastic bags, carton boxes and wood pallets) SHOULD BE KEPT OUTSIDE THE REACH OF CHILDREN, AS THEY ARE A SOURCE OF POTENTIAL HAZARD.**

## INSTALLATION

**THIS ICE MAKER IS NOT DESIGNED FOR OUTDOOR OPERATION.**

**An incorrect installation of the equipment may cause damages to individuals, animals or other materials, being the manufacturer not responsible for such damages.**

### CAUTION:

The machines are designed to operate at room temperature between 5°C (41°F) and 43°C (109.40°F), with inlet water temperature between 5°C (41°F) and 35°C (95°F).

The reduction motor is excessively forced if operated under the minimum temperatures. Above the maximum temperature, the life of the compressor is shortened and the production is substantially less.

Do not place anything over the maker or facing the front louver.

In case the front louver is not enough, the exit is either total or partially obstructed or due to its placement it will receive hot air from another device, we recommend, in case it is not possible to change the location of the machine, **TO INSTALL A WATER CONDENSER.**

**IT IS IMPORTANT THAT THE WATER PIPING DO NOT PASS BY OR NEAR SOURCES OF HEAT SO AS NOT TO LOSE ICE PRODUCTION.**

**THREAD THE SUPPORT LEGS TO THE BASE OF THE MACHINE ON THE HOUSING SET TO SUCH END AND REGULATE THE HEIGHT AS TO HAVE THE EQUIPMENT PERFECTLY LEVELED.**

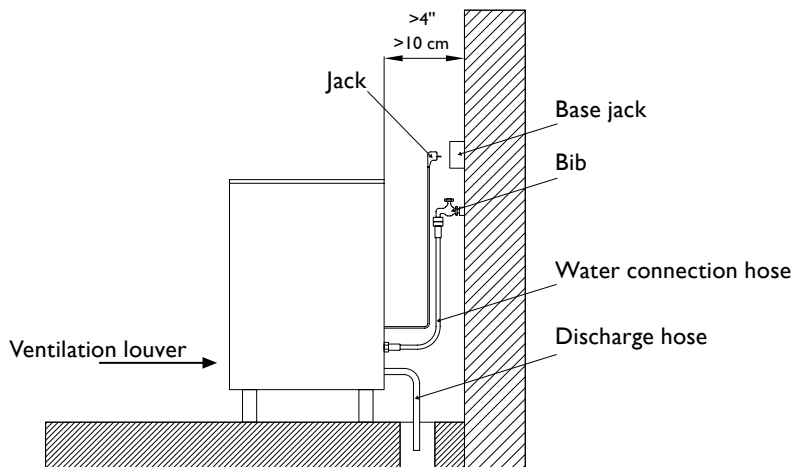

## IN MODULAR MACHINES

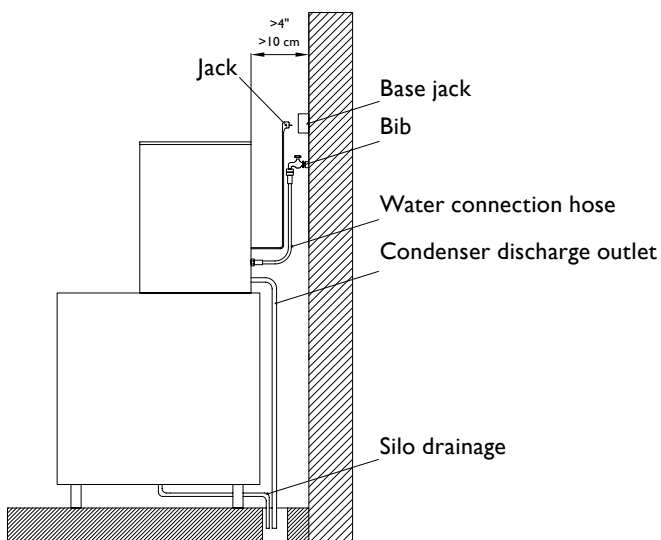

## I. WATER AND DRAINAGE

Water quality has a remarkable influence on the appearance, hardness and flavor of the ice as well as, on the machines condensed by water, on the life of the condenser.

## 2. CONNECTIONS TO THE WATER NETWORK

Use a flexible pipe (1.3 m – 4.27 feet length) with the two filter joints supplied with the machine. We strongly discourage the use of two-exit bibs and two switches as, due to an error could close that back one, leaving the machine without water supply. This could result on a damage call without actually existing one.

Pressure should be established between 0.7 and 6 Bar (10 / 85 psi.)

If pressures overpass such values, install the necessary corrective devices.

INSTALL A 10  $\mu$  PARTICLE FILTER INCLUDED IN THE KIT.

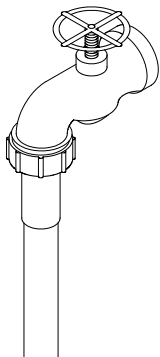
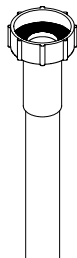
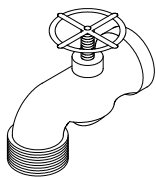

## 3. CONNECTION TO DRAINAGE

Drainage should be located lower to the machine level, at 150 mm (5.91 inches) minimum. It is convenient that the drainage pipe is of 30 mm (1.18 in) of interior diameter and with a minimum gradient of 3 cm (1.18 in) per meter (see figure).

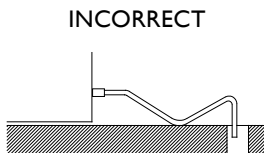
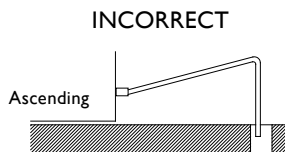
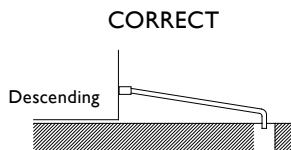

## 4. ELECTRICAL CONNECTION

### IT IS MANDATORY TO GROUND THE EQUIPMENT.

To avoid possible discharges on individuals or damages to the equipment, the machine should be grounded pursuant local and/or national regulations as the case may be.

**THE MANUFACTURER SHALL BE HELD HARMLESS IN CASE OF DAMAGES ARISING DUE TO THE LACK OF THE GROUND INSTALLATION.**

The machine is supplied with a 1.5 m (4.92 feet) cable of length. In case the supply cable is damaged, it should be replaced by a cable of special assembly to be furnished by the manufacturer or post-sale service. Such replacement should be performed by qualified technical service only.

The machine should be placed in such a way as to allow a minimum space between the back and the wall to allow an easy access and without risks to the cable jack.

Safeguard the base of the jack.

It is convenient to install adequate switches and fuses.

The line up to the jack should have a minimum section of 2.5 mm<sup>2</sup> (0.0038 in<sup>2</sup>)

**Voltage and tension are indicated in the nameplate and on the technical specifications of this manual. Variation on voltage above the 10% stated on the nameplate could result on damages or prevent the machine start-up.**

## 5. INSTALLATION OF MODULAR EQUIPMENTS OVER DEPOSITS OR SILOS

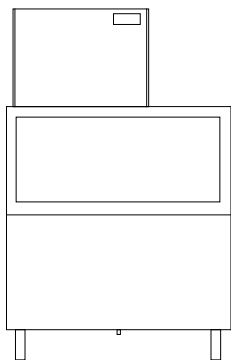

Modular makers should be installed over deposits or silos, following the instructions contained in this manual.

The resistance and stability of the container-machine/s assembly should be verified, as well as the fastening elements.

## 6. ASSEMBLY OF THE DISPERSION CONE (MODULAR MODELS)

This device distributes the ice in the silos, and avoids ice compression under the exit pipe.

Changing its position, the ice could be directed to any direction.

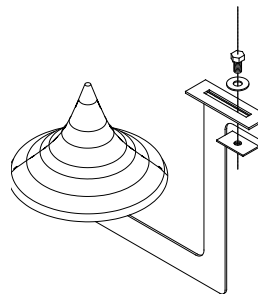

## 7. WATER LEVEL

The function of the water level is to maintain the necessary flow on the evaporator, and using the magnetic micro device incorporated, stop the operation of the machine until the water reaches again the container. The models 400, 550 and 1100 have a water pressostat replacing the micro-magnetic. The optimum level is located on the horizontal indicated in the figure, and its regulation is made following the indications appearing below.

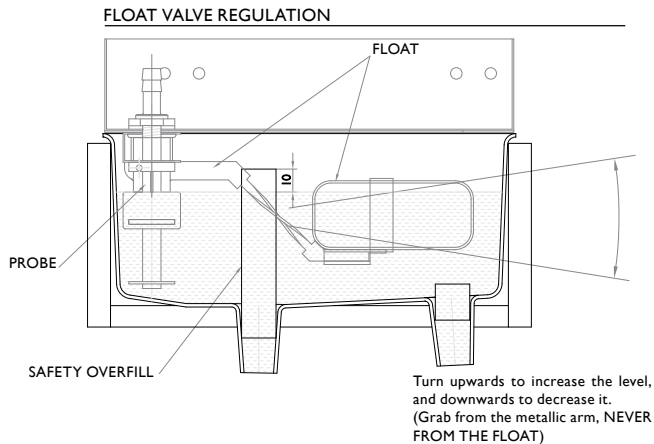

## START-UP

### I. Previous Checkup

- a) Is the machine leveled?
- b) Voltage and frequency are the same as those on the nameplate?
- c) Are the discharges connected and operating?
- d) \*\* If air condensed: Is the air circulation and its temperature appropriate?

	ROOM	WATER
MAXIMUM	43°C / 109,40°F	35°C / 95°F
MINIMUM	5°C / 41°F	5°C / 41°F

- e) \*\* Is water pressure appropriate?

MINIMUM	0,7 Bar (10 psi)
MAXIMUM	6 Bar (85 psi)

**NOTE:** In case input water pressure is higher that 6 Bar (85 psi), install a pressure reducer. THE BIBB CONNECTION PRESSURE SHOULD NEVER BE REDUCED.



## 2. Start-up

Once the installation instructions are followed (ventilation, site conditions, temperatures, water quality, etc.), proceed as follows:

1. In the case of modular modules, remove the cover to access the installation kit (filters, connection hoses, dispersion cones, etc.).
2. In case of compact models, open the deposit door to access the installation kit.
3. Open the water inlet. Verify the existence of leakages.
4. Connect the machine to the electrical network.
5. Verify that there are no vibrations or frictions on the elements.
6. After the 10 minutes of the timer installed in the electric panel, the machine will start the operation.
7. In the case of modular models (mainly in three-phase equipments), having the cover removed, verify that the motor is rotating in the correct direction.
8. Verify that after 15 minutes, the frost on the aspiration pipe is at 20 mm (0.78 in) of the compressor.

### **CAUTION:**

**INSTRUCT THE USER ABOUT MAINTENANCE, INFORMING THAT MAINTENANCE AND CLEANING OPERATION AS WELL AS DAMAGES DUE TO THE LACK OF SUCH OPERATIONS: ARE NOT INCLUDED ON THE WARRANTY.**

The technical installer shall invoice traveling costs, hours and materials used on such operations.

## **MAINTENANCE AND CLEANING INSTRUCTIONS**

---

**CAUTION:** Maintenance and cleaning operations and damages as the lack of those activities: Are not included on the warranty.

If a good maintenance is performed, the machine will continue producing a good quality ice and will be free of damages.

Maintenance and cleaning intervals will depend on the conditions of the location and water quality.

**CAUTION:** At least, one revision and cleaning should be performed every six months.

On dusty environments, it might be necessary to clean the condenser on a monthly basis.

### **MAINTENANCE AND CLEANING PROCEDURES:**

**\*\* CAUTION:** For all cleaning and maintenance operations: Disconnect the machine from the power supply.

## **1. Water condenser**

1. Disconnect the machine.
2. Disconnect the water inlet or close the bibb.
3. Disconnect the water inlet and outlet from the condenser.
4. Prepare a solution at the 50% of phosphoric acid and distilled or demineralized water.
5. Make the solution circulate through the condenser. (The solution is more effective if hot – between 35°C [95°F] and 40°C [104°F]).

### **DO NOT USE HYDROCHLORIC ACID.**

## **2. Air Condenser**

1. Disconnect the machine.
2. Disconnect the water inlet or close the bibb.
3. Clean the louvered area with the help of an aspirator with a brush, non-metallic brush or low-pressure air.

## **3. Cleaning the Stock Container (Compact models)**

1. Disconnect the machine, close the water and empty the ice-cube stock.
2. Use a dishcloth and bleach with detergent.

## **4. Exterior Cleaning**

Use the same procedure as the one indicated for the container.

## **5. Cleaning of the Inlet Filters**

They are easily obstructed during the first days of operation, MAINLY WITH NEW PIPING INSTALLATIONS.

Loose the hose and clean it under water.

## **6. Water Leak Control**

When working on the machine, always check the water connections, status of the clamps and hoses with the purpose of avoiding leakages and prevent damages or floods.

## PANELES DE CONTROL / CONTROL PANEL

### I. MODELO 45-CD50 / MODEL 45-CD50

**Piloto verde:** Indica que la máquina está activada. Puede estar parada por termostato de stock.

**Pulsador negro:** Pone la máquina en funcionamiento. También rearma la máquina cuando está parada por algún elemento de seguridad.

**Pulsador rojo:** Para la máquina completamente.

**Green Led:** Indicates that the machine is activated. Might be stopped due to the bin thermostat

**Black Switch:** Starts the operation of the machine. Also rearms the machine when it is stopped by some security element.

**Red Switch:** Stops the machine completely

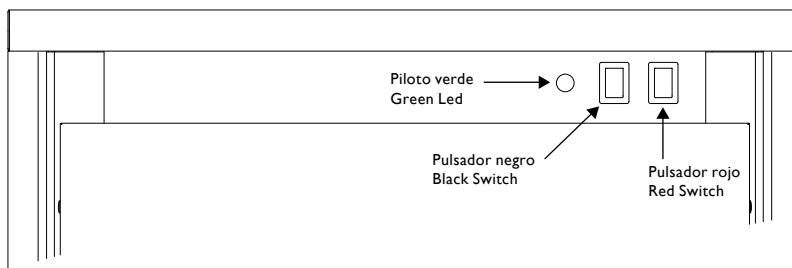

### 2. MODELO 85-CD90 / MODEL 85-CD90

**Pulsador verde:** Pone la máquina en funcionamiento indicándonoslo con el piloto encendido.

**Piloto rojo:** Nos indica que la máquina está parada por algún elemento de seguridad

**Piloto naranja:** Nos indica cuando el almacén de hielo está lleno.

**Green Switch:** Starts the operation of the machine. It is indicated with the led on.

**Red Led:** Indicates that the machine is stopped by a security element.

**Orange Led:** Indicates that the storage bin is full of ice.

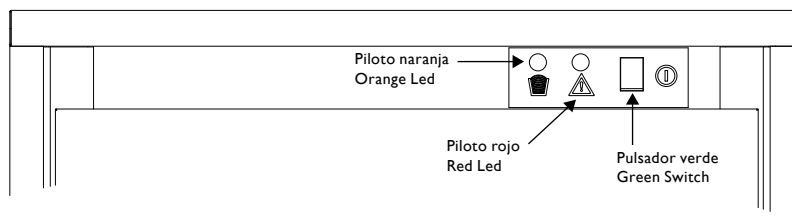

# ESQUEMAS ELÉCTRICOS / WIRING DIAGRAM

## 45-CD50

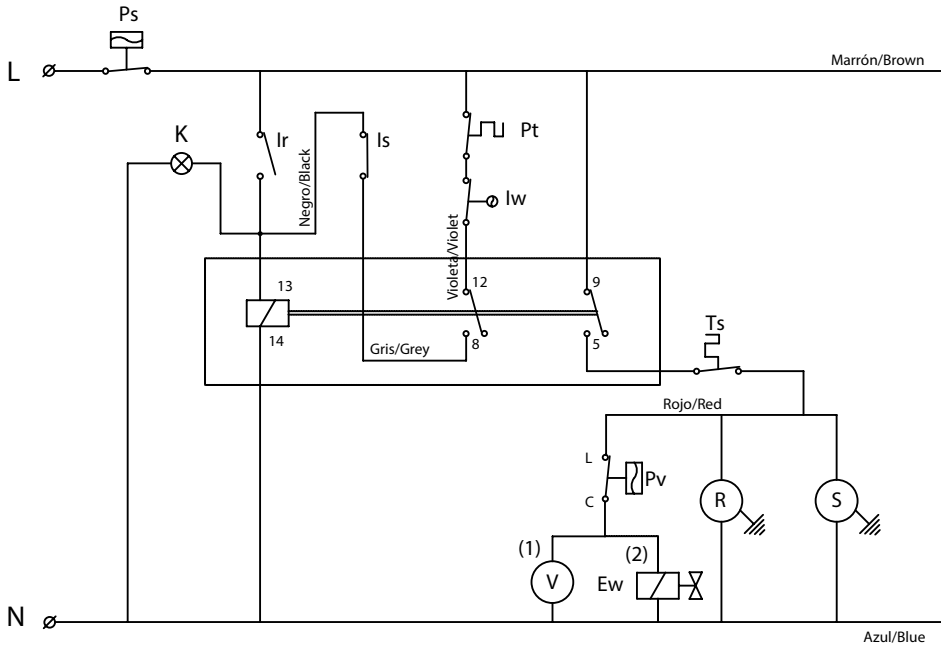

- (1) SÓLO MÁQUINAS CONDENSADAS POR AIRE  
 (2) SÓLO MÁQUINAS CONDENSADAS POR AGUA

- (1) ONLY AIR COOLED MODELS  
 (2) ONLY WATER COOLED MODELS

Pv. -Presostato ventilador  
 V. -Ventilador  
 Ew. -Electroválvula condensación  
 S. -Compresor  
 Ir. -Interrupor de marcha  
 Is. -Interrupor de paro  
 Ts. -Paro por llenado  
 lw. -Micro boya falta de agua  
 Ps. -Presostato de seguridad  
 R. -Motorreductor  
 Pt. - Protector térmico motor  
 K. -LED Verde línea

Pv. -Fan pressostat  
 V. -Fan  
 Ew. -Condenser water valve  
 S. -Compressor  
 Ir. -On switch  
 Is. -Off switch  
 Ts. -Full storage bin stop  
 lw. -Water low level float switch  
 Ps. -High pressure safety pressostat  
 R. -Gearmotor  
 Pt. -Motor thermal protection  
 K. LED Green on

# 85-CD90

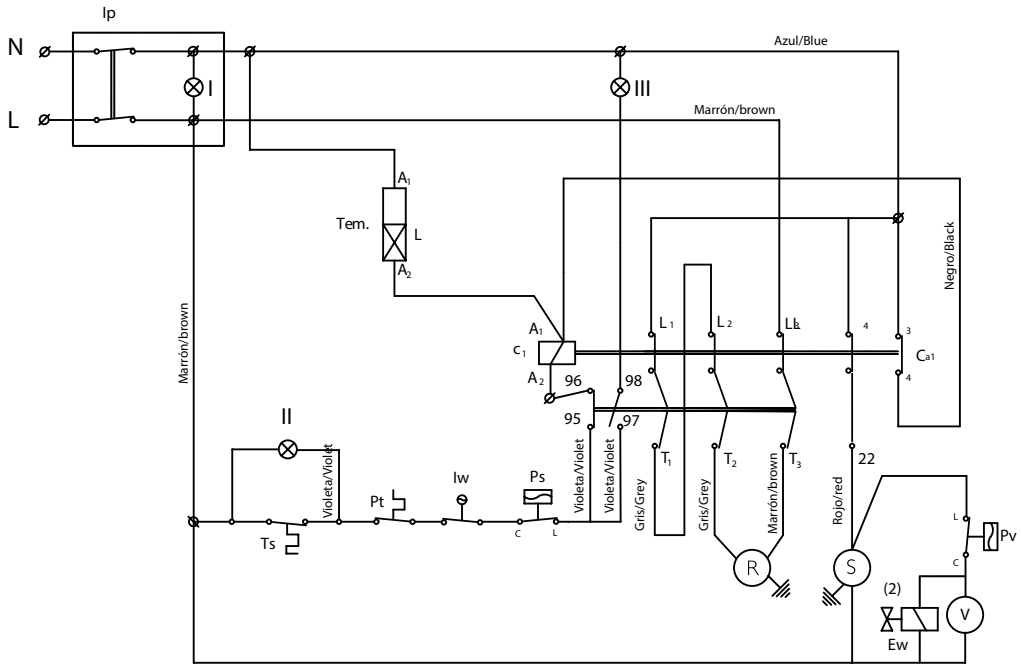

Tem. -Temporizador a la conexión  
 C1 -Contactor  
 Pv. -Presostato ventilador (sólo cond.por aire)  
 V. -Ventilador  
 S. -Compresor  
 Ip. -Interruptor de paro-marcha  
 Ts. -Paro por llenado  
 lw. -Micro boya falta de agua  
 Ps. -Presostato de seguridad  
 R. -Motoreductor  
 Pt. -Protector térmico motor  
 Ew. -Electroválvula condensación

Tem. -Start timer  
 C1 -Contactor  
 Pv. -Fan pressostat (only air cooled models)  
 V. -Fan  
 S. -Compressor  
 Ip. -On/off switch  
 Ts. -Full storage bin stop  
 lw.- Water low level float switch  
 Ps. -High pressure safety pressostat  
 R. -Gearmotor  
 Pt. -Motor thermal protection  
 Ew. -Condenser water valve

I -Verde linea / Green on  
 II -Ambar llenado/ Yellow full  
 III -Termico Motorreductor/Thermic gearmotor

# MONOFÁSICA / MONOPHASE

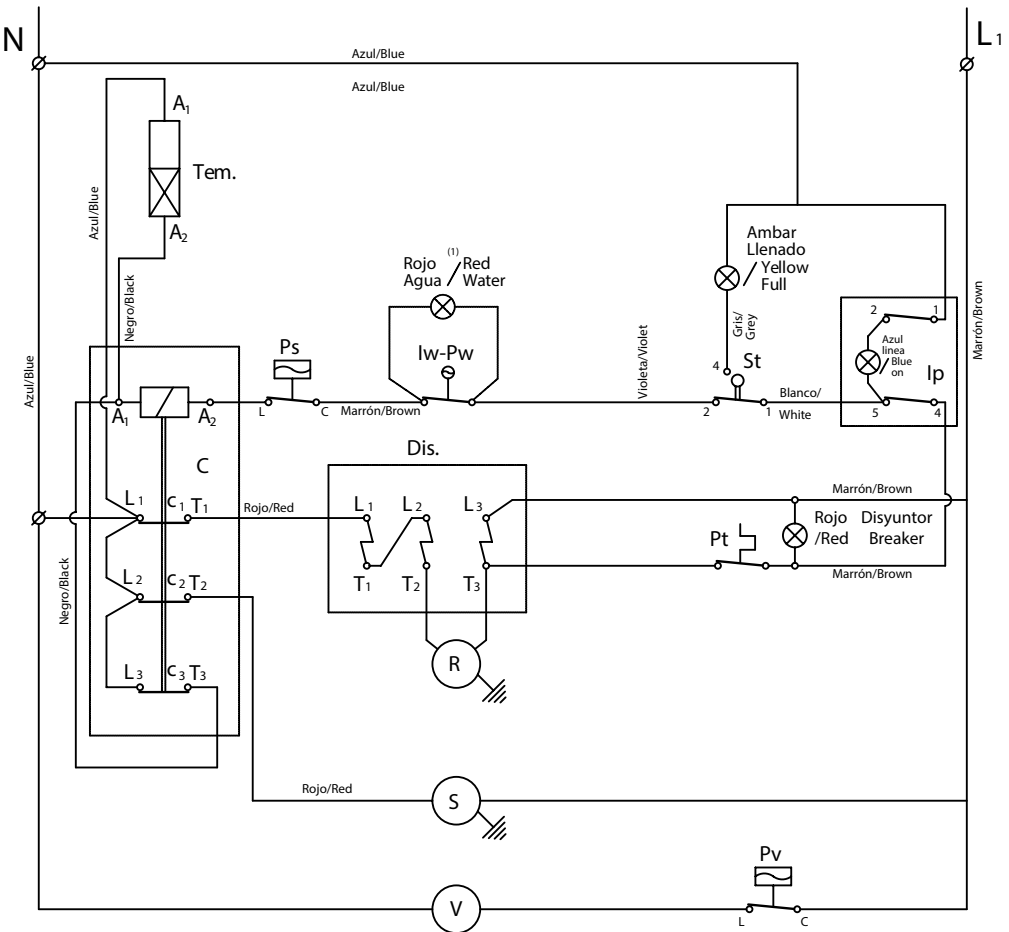

(1)SÓLO EN LA IQ550-GR560S / ONLY IQ550-GR560S

- Tem. -Temporizador a la conexion
- C. -Contactor
- c1 -Contacto (Motorreductor)
- c2 -Contacto (Compresor)
- c3 -Contacto autoalimentacion
- Dis. -Disyuntor (Motorreductor)
- Pv. -Presostato ventilador (solo cond.por aire)
- V. -Ventilador
- S. -Compresor
- Ip. -Interruptor de paro-marcha
- St. -Paro por llenado
- Iw. -Micro boya falta de agua
- Pw. -Presostato de agua (IQ400/550-GR560S)
- Ps. -Presostato de seguridad
- R. -Motorreductor
- Pt. -Protector térmico motor

- Tem. -Start timer
- C. -Contactor
- c1 -contact (gearmotor)
- c2 -Contact (Compressor)
- c3 -Feedback contact
- Dis. -Circuit Breaker (motorgear)
- Pv. -Fan pressostat (only air cooled models)
- V. -Fan
- S. -Compressor
- Ip. -On/off switch
- St. -Full storage bin stop
- Iw. -Water low level float switch
- Pw. -Water pressostat (IQ400/550-GR560S)
- Ps. -High pressure safety pressostat
- R. -Gearmotor
- Pt. -Motor thermal protection

# 400/550-GR560 R404A TRIFÁSICA / 400/550-GR560 R404A TRIPHASE

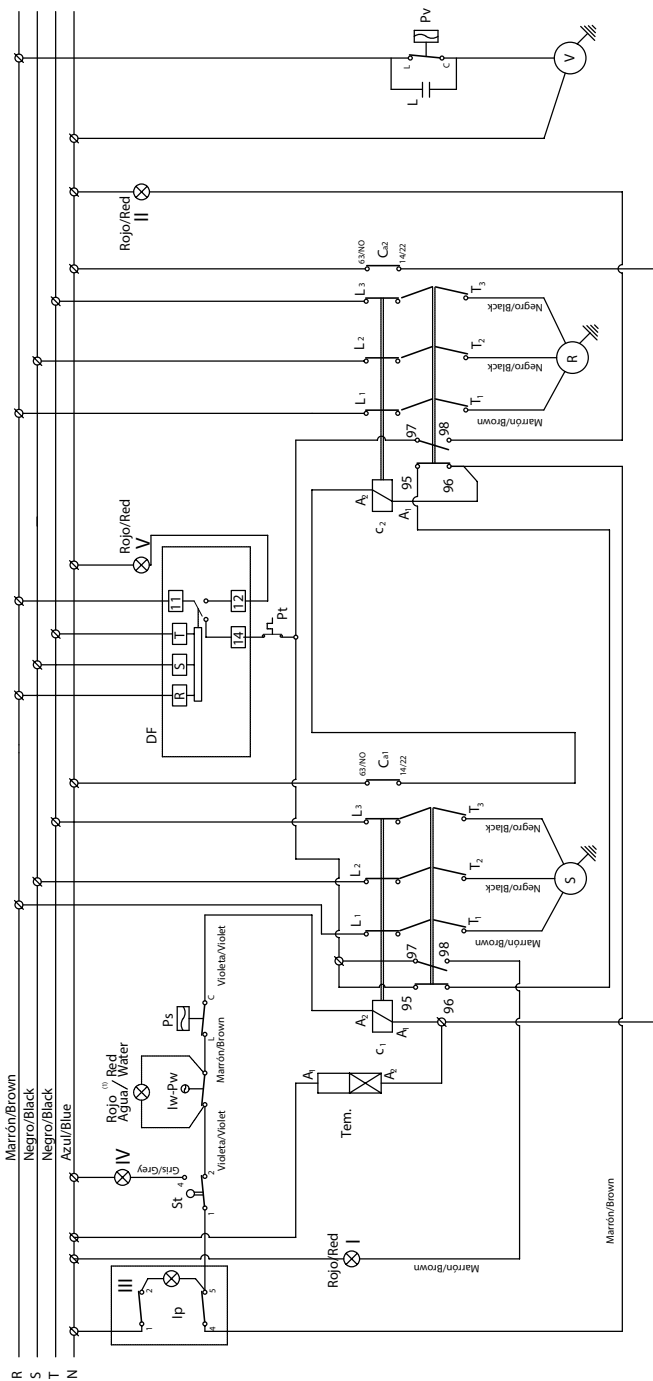

REGULACION TERMICOS OVERLOAD SETTING	
COMPRESOR	3,6 A
MOTORREDUCTOR	1,3 A

- Tem. - Temporizador a la conexion/Start Timer
- C1 - Contactor (Compresor)/Contact (Compressor)
- C2 - Contactor (Motorreductor)/Contact (Gearmotor)
- Pw - Presostato ventilador (sólo condop por aire)/Fan Pressostat (only air cooled models)
- V. - Ventilador/Fan
- S. - Compresor/Compressor
- Ip. - Interruptor de paro-marcial/On-off switch
- St. - Paro por llenado/Full storage bin stop
- Iw. - Micro boya falta de agua/Water low level float switch
- Pw. - Presostato de agua/Water pressostat
- Ps. - Presostato de seguridad/High pressure safety pressostat
- R. - Motorreductor/Gearmotor
- L. - Condensador filtro/Electrical interference filter (capacitador)
- Pt. - Protector térmico motor/Motor thermal protection
- Df. - Detector de fase/Phase sequence relay
- Ca1 - Contacto auxiliar autoalimentacion/Auxiliar contact feedback
- Ca2 - Contacto auxiliar autoalimentacion/Auxiliar contact feedback
- I - Térmico compresor/Thermic compressor
- II - Térmico Motorreductor/Thermic gearmotor
- III - Azul linea / Blue on
- IV - Ambar llenado/ Yellow full
- V - Fase cambia/Phase sequence

01/02/2011





# 1100 R404A TRIFÁSICA / 1100 R404A TRIPHASE

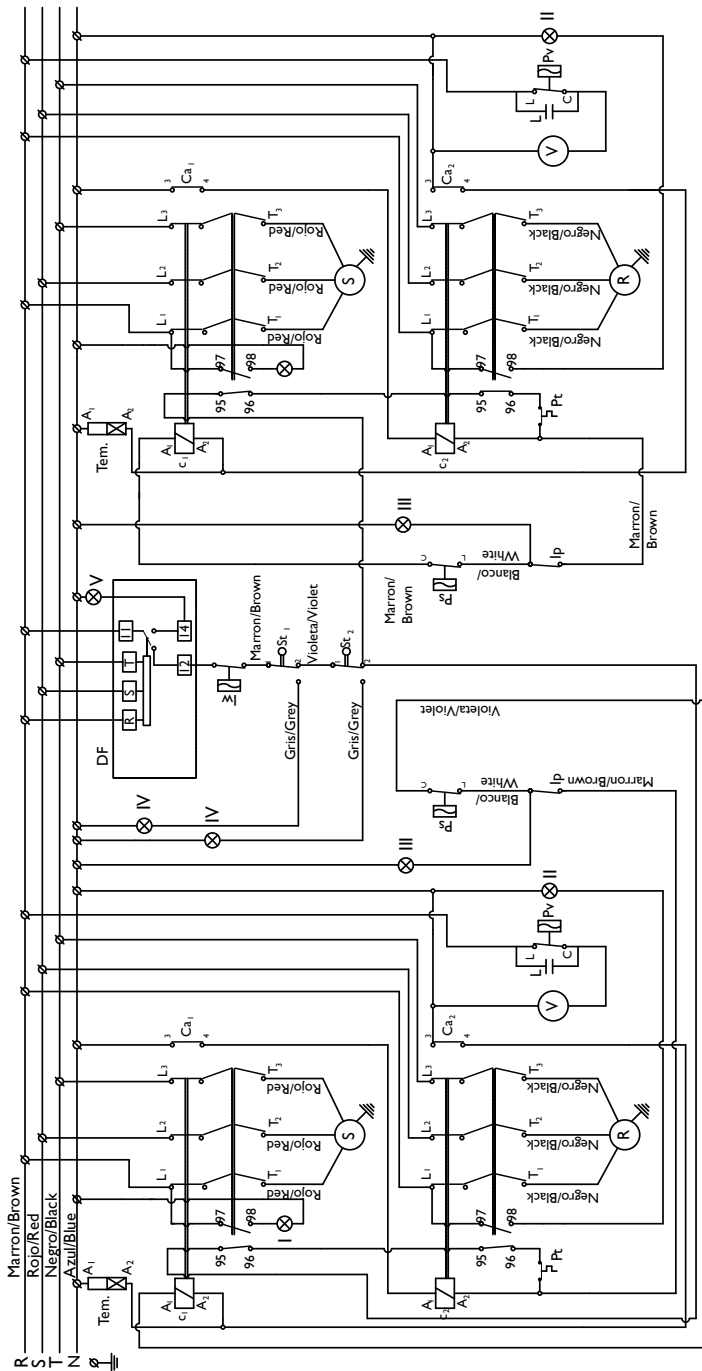

REGULACION TERMINOS OVERLOAD SETTING	
COMPRESOR / COMPRESSOR	36A
MOTOR REDUCTOR / GEARMOTOR	1.3A

- Condensador-filtro / Electrical interference filter (capacitador)
- Protector térmico motor / Motor thermal protection
- Detector de fase / Phase sequence relay
- Cal
- Contacto auxiliar motor reductor / Auxiliar contact gearmotor
- Contacto auxiliar autoalimentación / Auxiliar contact feedback
- Térmico compresor / Thermic compressor
- Verdigoso / Green
- Marron/Brown / Yellow full
- Fase cambia / Phase sequence

- Temporizador a la conexión / Start timer
- Contactor (motorreductor) / Contact (gearmotor)
- Compresor (compresor) / Compressor
- P.V.
- Ventilador / Fan
- Compresor
- Interrupción de par-marcha / On-off switch
- P.V.
- P.V.
- Presostato falta de agua / Water low pressure switch
- Presostato de seguridad / High pressure safety pressostat
- Motorreductor / Gearmotor

15-09-08

# GENERADOR I100 / GENERATOR I100

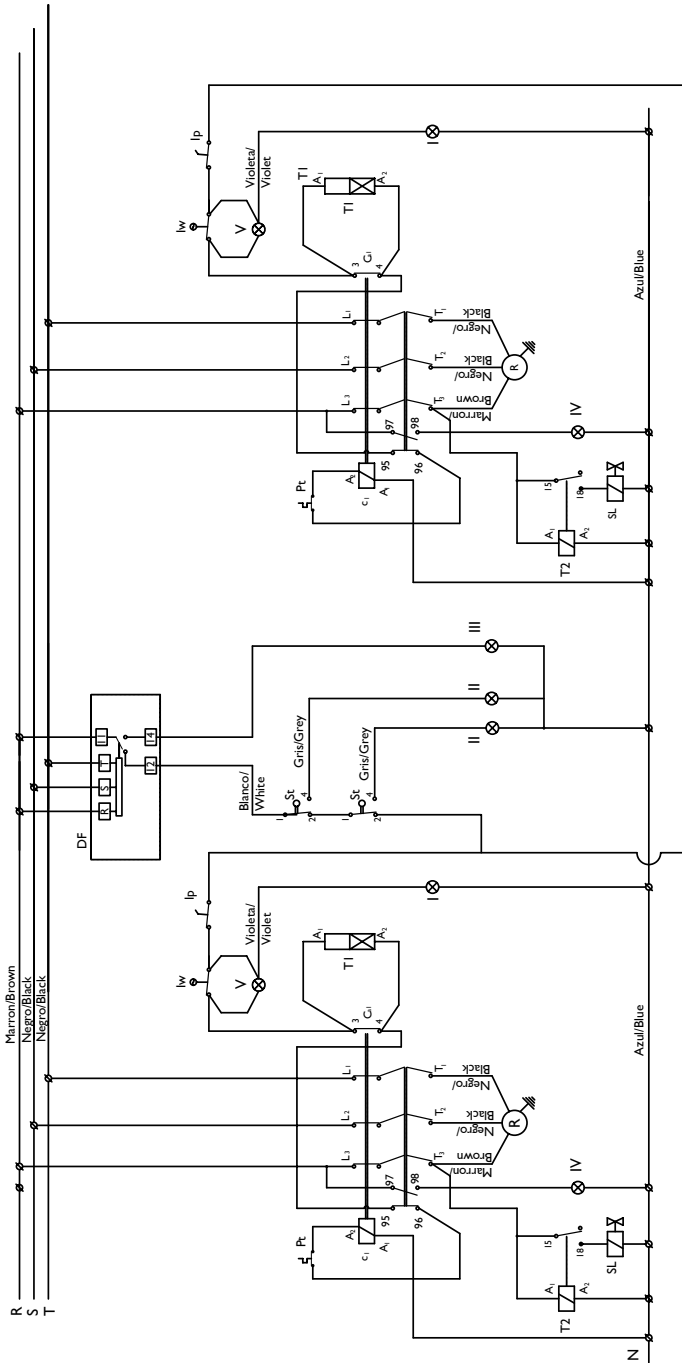

13-12-08

- Detector de fase / Phase sequence relay
- Contacto auxiliar motorreductor / Auxiliar contact gearmotor
- Verde línea / Green on
- Anbar llenado / Yellow full
- Fase cambia / Phase sequence
- Térmico motorreductor/ Thermic gearmotor
- Agua / Water

- DF:
- Ca1
- I
- II
- III
- IV
- V

- Temporizador a la conexión / Start timer
- Temporizador válvula líquido / Liquid valve timer
- Protector térmico motor / Motor thermal protection
- Interruptor de paro-marcha / On-off switch
- Puro por llenado / Full storage bin stop
- Micro boya falta de agua / Water low level float switch
- Motorreductor / Gearmotor

- T1
- T2
- Pt
- Ip
- Iv
- R.

**D** In Übereinstimmung mit den Anforderungen der Europäischen Richtlinie 2002/96/EG über Elektro- und Elektronik-Altgeräte (WEEE) ist vorliegendes Gerät mit einer Markierung versehen. Sie leisten einen positiven Beitrag für den Schutz der Umwelt und die Gesundheit des Menschen, wenn Sie dieses Gerät einer gesonderten Abfallsammlung zuführen. Im unsortierten Siedlungsmüll könnte ein solches Gerät durch unsachgemäße Entsorgung negative Konsequenzen nach sich ziehen. Auf dem Produkt oder der beiliegenden Produktdokumentation ist

folgendes Symbol  einer durchgestrichenen Abfalltonne abgebildet. Es weist darauf hin, dass eine Entsorgung im normalen Haushaltsabfall nicht zulässig ist. Entsorgen Sie dieses Produkt im Recyclinghof mit einer getrennten Sammlung für Elektro- und Elektronikgeräte. Die Entsorgung muss gemäß den örtlichen Bestimmungen zur Abfallbeseitigung erfolgen. Bitte wenden Sie sich an die zuständigen Behörden Ihrer Gemeindeverwaltung, an den lokalen Recyclinghof für Haushaltsmüll oder an den Händler, bei dem Sie dieses Gerät erworben haben, um weitere Informationen über Behandlung, Verwertung und Wiederverwendung dieses Produkts zu erhalten.

**GB** This appliance is marked according to the European directive 2002/96/EC on Waste Electrical and Electronic Equipment (WEEE). By ensuring this product is disposed of correctly, you will help prevent potential negative consequences for the environment and human health, which could otherwise be caused by inappropriate waste handling of this product.

The symbol  on the product, or on the documents accompanying the product, indicates that this appliance may not be treated as household waste. Instead it shall be handed over to the applicable collection point for the recycling of electrical and electronic equipment. Disposal must be carried out in accordance with local environmental regulations for waste disposal. For more detailed information about treatment, recovery and recycling of this product, please contact your local city office, your household waste disposal service or the shop where you purchased the product.

**F** Cet appareil porte le symbole du recyclage conformément à la Directive Européenne 2002/96/CE concernant les Déchets d'Équipements Électriques et Électroniques (DEEE ou WEEE). En procédant correctement à la mise au rebut de cet appareil, vous contribuez à empêcher toute conséquence nuisible pour l'environnement et la santé de l'homme.

Le symbole  présent sur l'appareil ou sur la documentation qui l'accompagne indique que ce produit ne peut en aucun cas être traité comme déchet ménager. Il doit par conséquent être remis à un centre de collecte des déchets chargé du recyclage des équipements électriques et électroniques. Pour la mise au rebut, respectez les normes relatives à l'élimination des déchets en vigueur dans le pays d'installation. Pour obtenir de plus amples détails au sujet du traitement, de la récupération et du recyclage de cet appareil, veuillez vous adresser au bureau compétent de votre commune, à la société de collecte des déchets ou directement à votre revendeur.

**NL** Dit apparaat is voorzien van het merkteken volgens de Europese richtlijn 2002/96/EG inzake Afgedankte elektrische en elektronische apparaten (AEEA). Door ervoor te zorgen dat dit product op de juiste manier als afval wordt verwerkt, helpt u mogelijk negatieve consequenties voor het milieu en de menselijke gezondheid te voorkomen die anders zouden kunnen worden veroorzaakt door onjuiste verwerking van dit product als afval.

Het symbool  op het product of op de bijbehorende documentatie geeft aan dat dit product niet als huishoudelijk afval mag worden behandeld. In plaats daarvan moet het worden afgegeven bij een verzamelpunt voor recycling van elektrische en elektronische apparaten. Afhandeling moet worden uitgevoerd in overeenstemming met de plaatselijke milieuvorschriften voor afvalverwerking. Voor nadere informatie over de behandeling, terugwinning en recycling van dit product wordt u verzocht contact op te nemen met het stadskantoor in uw woonplaats, uw afvalophaaldienst of de winkel waar u het product heeft aangeschaft.

**E** Este aparato lleva el marcado CE en conformidad con la Directiva 2002/96/EC del Parlamento Europeo y del Consejo sobre residuos de aparatos eléctricos y electrónicos (RAEE). La correcta eliminación de este producto evita consecuencias negativas para el medioambiente y la salud.

El símbolo  en el producto o en los documentos que se incluyen con el producto, indica que no se puede tratar como residuo doméstico. Es necesario entregarlo en un punto de recogida para reciclar aparatos eléctricos y electrónicos. Deséchelo con arreglo a las normas medioambientales para eliminación de residuos. Para obtener información más detallada sobre el tratamiento, recuperación y reciclaje de este producto, póngase en contacto con el ayuntamiento, con el servicio de eliminación de residuos urbanos o la tienda donde adquirió el producto.

**P** Este aparelho está classificado de acordo com a Directiva Europeia 2002/96/EC sobre Resíduos de equipamento eléctrico e electrónico (REEE). Ao garantir a eliminação adequada deste produto, estará a ajudar a evitar potenciais consequências negativas para o ambiente e para a saúde pública, que poderiam derivar de um manuseamento de desperdícios inadequado deste produto.

O símbolo  no produto, ou nos documentos que acompanham o produto, indica que este aparelho não pode receber um tratamento semelhante ao de um desperdício doméstico. Pelo contrário, deverá ser depositado no respectivo centro de recolha para a reciclagem de equipamento eléctrico e electrónico. A eliminação deverá ser efectuada em conformidade com as normas ambientais locais para a eliminação de desperdícios. Para obter informações mais detalhadas sobre o tratamento, a recuperação e a reciclagem deste produto, contacte o Departamento na sua localidade, o seu serviço de eliminação de desperdícios domésticos ou a loja onde adquiriu o produto.

**I** Questo apparecchio è contrassegnato in conformità alla Direttiva Europea 2002/96/EC, Waste Electrical and Electronic Equipment (WEEE). Assicurandosi che questo prodotto sia smaltito in modo corretto, l'utente contribuisce a prevenire le potenziali conseguenze negative per l'ambiente e la salute.

Il simbolo  sul prodotto o sulla documentazione di accompagnamento indica che questo prodotto non deve essere trattato come rifiuto domestico ma deve essere consegnato presso l'adeguato punto di raccolta per il riciclaggio di apparecchiature elettriche ed elettroniche. Difarsene seguendo le normative locali per lo smaltimento dei rifiuti. Per ulteriori informazioni sul trattamento, recupero e riciclaggio di questo prodotto, contattare l'adeguato ufficio locale, il servizio di raccolta dei rifiuti domestici o il negozio presso il quale il prodotto è stato acquistato.

**GR** Αυτή η συσκευή φέρει σήμανση σύμφωνα με την Ευρωπαϊκή οδηγία 2002/96/ΕΕ σχετικά με Απορριπόμενα Ηλεκτρικά και Ηλεκτρονικά Εξαρτήματα (WEEE). Εξασφαλίζοντας ότι το προϊόν αυτό απορριπτεί ουσιά, θα βοηθήσετε στην πρόληψη πιθανών αρνητικών επιπτώσεων για το περιβάλλον και την ανθρώπινη υγεία, οι οποίες θα μπορούσαν να δημιουργηθούν από τον ακατάλληλο χειρισμό αυτού του προϊόντος ως απορρίμμα.

Το σύμβολο  πάνω στο προϊόν, ή στα έγγραφα που συνοδεύουν το προϊόν, υποδεικνύει ότι αυτή η συσκευή δεν μπορεί να θεωρηθεί οικιακό απόρριμμα. Αντι ή αυτό θα πρέπει να παραδοθεί στο κατάλληλο σημείο περισυλλογής για την ανακύκλωση των ηλεκτρικών και ηλεκτρονικών εξαρτημάτων. Διαλύστε το προϊόντος την τοπική νομοθεσία για τη διάθεση των απορριμμάτων. Για πιο λεπτομερείς πληροφορίες σχετικά με την επεξεργασία, την περισυλλογή και την ανακύκλωση αυτού του προϊόντος, παρακαλούμε επικοινωνήστε με το αρμόδιο γραφείο της τοπικής σας αυτοδιοίκησης, την τοπική σας υπηρεσία αποκομιδής οικιακών απορριμμάτων ή το κατάστημα όπου αγοράσατε αυτό το προϊόν.

**S** Denna produkt är märkt enligt EG-direktiv 2002/96/EEC beträffande elektriskt och elektroniskt avfall (Waste Electrical and Electronic Equipment, WEEE). Genom att säkerställa en korrekt kassering av denna produkt bidrar du till att förhindra potentiella, negativa konsekvenser för vår miljö och vår hälsa, som annars kan bli följden om produkten inte hanteras på rätt sätt.

Symbolen  på produkten, eller i medföljande dokumentation, indikerar att denna produkt inte får behandlas som vanligt hushållsavfall. Den skall i stället lämnas in på en lämplig uppsamlingsplats för återvinning av elektrisk och elektronisk utrustning. Produkten måste kasseras enligt lokala miljöbestämmelser för avfallshantering. För mer information om hantering, återvinning och återanvändning av denna produkt, var god kontakta de lokala myndigheterna, ortens sophanteringstjänst eller butiken där produkten inhandlades.

**N** Dette apparatet er mærket i samsvar med EU-direktiv 2002/96/EC om afhending af elektrisk og elektronisk udstyr (Waste Electrical and Electronic Equipment - WEEE). Forsikre dig om at dette produktet blir afhendet på korrekt vis, slik at det ikke kan utgjøre noen helse- eller miljørisiko.

Symbol  på produktet eller på dokumentene som følger med det, viser at dette produktet ikke må behandles som husholdningsavfall. Lever det til et autorisert mottak for resirkulering av elektrisk og elektronisk utstyr. Anvendning må skje iht. de lokale renovasjonsforskriftene. For nærmere informasjon om håndtering, kassering og resirkulering av dette produktet, kontakt kommunen, renovasjonsvesenet eller forretningen der du anskaffet det.

**DK** Dette produkt er mærket i henhold til EU-direktiv 2002/96/EF om Kasseret elektrisk og elektronisk udstyr (WEEE). Ved at sikre, at dette produkt bliver skrotet korrekt, hjælper man med til at forhindre potentielle, negative konsekvenser for miljøet og folkesundheden, der kunne opstå gennem uhensigtsmæssig bortskaffelse af dette produkt.

Symbol  på produktet eller på dokumenterne, der ledsager produktet, angiver, at produktet ikke må bortskaffes sammen med husholdningsaffaldet. Det skal i stedet anleveres på en genbrugsstation for elektrisk og elektronisk udstyr. Det skal skrottes i henhold til gældende lokale miljøregler for bortskaffelse af affald.

For yderligere oplysninger om håndtering, genvinding og genbrug af dette produkt bedes man kontakte de lokale myndigheder, renovationssekskabet eller forretningen, hvor produktet er købt.

**FIN** Tämä laite on merkitty WEEE-direktiivin (Waste Electrical and Electronic Equipment) 2002/96/EC mukaisesti. Varmistamalla, että tuote poistetaan käytöstä asianmukaisesti, voidaan auttaa estämään sellaiset ympäristö- ja terveyshaitat, jotka saattaisivat aiheutua jätteiden asiattomasta käsittelystä.

Symbol  tuotteessa tai sen dokumentaatioissa tarkoittaa, ettei laitetta saa hävittää kotitalousjätteiden mukana. Sen sijaan tuote on toimitettava sähkö- ja elektroniikkakomponenttien keräys- ja kierrätyspisteeseen. Laitteen käytöstä poistoon suhteen on noudatettava paikallisia jätehuoltomääräyksiä.

Lisätietoja tuotteen käsittelystä, talteenotosta ja kierrätyksestä saa kaupungin- tai kunnanvirastosta, paikallisesta ympäristöliikkeestä tai liikkeestä, josta tuote ostettiin.

**PL** Niniejsze urządzenie posiada oznaczenia zgodnie z Dyrektywą Europejską 2002/96/EC w sprawie zużytego sprzętu elektrycznego i elektronicznego (WEEE). Zapewniając prawidłowe złomowanie niniejszego urządzenia przyczynią się Państwo do ograniczenia ryzyka wystąpienia negatywnego wpływu produktu na środowisko i zdrowie ludzi, które mogłoby zaistnieć w przypadku niewłaściwej utylizacji urządzenia.

Symbol  umieszczony na produkcie lub na dołączonych do niego dokumentach oznacza, że niniejszy produkt nie jest klasyfikowany jako odpad z gospodarstwa domowego.

Urządzenie, w celu jego złomowania, należy zdać w odpowiednim punkcie utylizacji odpadów w celu recyklingu komponentów elektrycznych i elektronicznych. Urządzenie należy złomować zgodnie z lokalnymi przepisami dot. utylizacji odpadów.

Dodatkowe informacje na temat utylizacji, złomowania i recyklingu opisywanego urządzenia można uzyskać w lokalnym urzędzie miasta, w większym przedsiębiorstwie utylizacji odpadów lub w sklepie, w którym produkt został zakupiony.

**CZ** Tento spotřebič je označen v souladu s evropskou směrnicí 2002/96/ES o likvidaci elektrického a elektronického zařízení (WEEE). Zajištěním správné likvidace tohoto výrobku pomůžete zabránit případným negativním důsledkům na životní prostředí a lidské zdraví, ke kterým by nevhodnou likvidací tohoto výrobku mohlo dojít.

Symbol  na výrobku nebo na dokumentech přiložených k výrobku udává, že tento spotřebič nepatří do domácího odpadu. Spotřebič je nutné odvézt do sběrného místa pro recyklaci elektrického a elektronického zařízení.

Likvidace musí být provedena v souladu s místními předpisy o ochraně životního prostředí, které se týkají likvidace odpadu. Podrobnější informace o zpracování, rekuperaci a recyklaci tohoto výrobku zjistíte u příslušného místního úřadu, služby pro likvidaci domovního odpadu nebo v obchodě, kde jste výrobek zakoupili.

**SK** Tento spotřebič je označen v súlade s Európskou smerecou 2002/96/ES o likvidácii elektrických a elektronických zariadení (WEEE). Zabezpečením, že tento výrobok bude zlikvidovaný správnym spôsobom, pomôžete predchádzať potenciálnym negatívnym dopadom na životné prostredie a ľudské zdravie, ktoré by sa v inom prípade mohli vyskytnúť pri nevhodnom zaobchádzaní pri likvidácii výrobku.

Symbol  na výrobku alebo na sprievodných dokumentoch znamená, že s týmto výrobkom sa nesmie zaobchádzať ako s domovým odpadom. Naopak, treba ho odovzdať v zbernom stredisku na recykláciu elektrických alebo elektronických zariadení. Likvidácia musí byť vykonaná v súlade s predpismi na ochranu životného prostredia pre likvidáciu odpadov.

Podrobnejšie informácie o zaobchádzaní, regenerácii a recyklácii tohto výrobku si vyzhľadajte na Vašom miestnom úrade, v zberných surovinách alebo v obchode, kde ste výrobok kúpili.

**H** A készülékben található jelzés megfelel az elektromos és elektronikus berendezések hulladékaróli szdó 2002/96/EK európai irányelvben (WEEE) foglalt előírásoknak. A hulladékká vált termék szabályszerű elhelyezésével Ön segít elkerülni a környezettel és az emberi egészséggel kapcsolatos azon esetleges negatív következményeket, amelyeket a termék nem megfelelő hulladékkezelése egyébként okozhatna. A terméken vagy a termékhez mellékelte dokumentumokon feltüntetett

jelzés arra utal, hogy ez a termék nem kezelhető háztartási hulladékként. Ehelyett a terméket a villamos és elektronikus berendezések újrahasonosítását végző telephely valamelyikén kell leadni.

Kiselejtezőskor a hulladékváltóállásra vonatkozó helyi környezetvédelmi előírások szerint kell eljárni. A termék kezelésével, hasznosításával és újrahasonosításával kapcsolatos bővebb tájékoztatásért forduljon a lakóhelye szarmiti polgármesteri hivatalhoz, a háztartási hulladékok kezelését végző társasághoz vagy ahhoz a bolthoz, ahol a terméket vásárolta.

**RUS** Данное изделие промаркировано в соответствии с Европейской директивой 2002/96/EC по утилизации электрического и электронного оборудования (WEEE). Обеспечив правильную утилизацию данного изделия, Вы можете предотвратить потенциальные негативные последствия для окружающей среды и здоровья человека, которые могли бы иметь место в противном случае.

Символ  на самом изделии или сопроводительной документации указывает, что при утилизации данного изделия с ним нельзя обращаться как с обычными бытовыми отходами. Вместо этого, его следует сдавать в соответствующий пункт приема электрического и электронного оборудования для последующей утилизации.

Сдача на слом должна производиться в соответствии с местными правилами по утилизации отходов. За более подробной информацией о правилах обращения с такими изделиями, их утилизации и переработки обращайтесь в местные органы власти, в службу по утилизации отходов или в магазин, в котором Вы приобрели данное изделие.

**BG** Този уред е маркиран в съответствие с Европейска директива 2002/96/EO "Електрическо и електронно оборудване за отпадъци" (WEEE). Като се погрижите това изделие да бъде изхвърлено по правилен начин, вие ще помогнете за предотвратяване на възможните негативни последици за околната среда и здравето на хората, което в противен случай може да бъде предизвикано от неправилно изхвърляне на това изделие.

Символът  върху изделието или върху документите, приложен ким изделието, показва, че това изделие не бива да се третира като битови отпадъци. Вместо това, то трябва да се предава в специализиран пункт за рециклиране на електрическо и електронно оборудване.

При изхвърлянето му спазвайте местните норми за изхвърляне на отпадъци. За по-подробна информация за транспортирането, встановяването и рециклирането на това изделие се обрънете към вашата местна градска управа, към вашата служба за изхвърляне на битови отпадъци или към магазина, откъдето сте закупили изделието.

**RO** Acest aparat este marcat în conformitate cu Directiva Europeană 2002/96/CE referitoare la Deșeurile de Echipament Electric și Electronic (WEEE). Asigurându-vă că acest produs este eliminat în mod corect, contribuiți la prevenirea potențialelor consecințe negative asupra mediului înconjurător și sănătății persoanelor, consecințe care ar putea fi provocate de ancurarea necorespunzătoare la gunoi a acestui produs.

Simbolul  de pe produs, sau de pe documentele care însoțesc produsul, indică faptul că acesta nu poate fi ancurat împreună cu deșeurile menajere. Trebuie predat la punctul de colectare corespunzător, pentru recidarea echipamentului electric și electronic.

Ancurarea la gunoi a aparatului trebuie făcută în conformitate cu normele locale pentru eliminarea deșeurilor. Pentru informații mai detaliate privind eliminarea, valorificarea și recidarea acestui produs, vă rugăm să contactați administrația locală, serviciul de eliminare a deșeurilor menajere sau magazinul de unde ați cumpărat produsul.



