













PS 122 230 V / 50 Hz

SELF-CONTAINED ICE CUBE MACHINE

FEATURES CARACTERÍSTICAS

- ▶ **PADDLE SYSTEM TO PRODUCE ICE IN THE MOST ADVERSE CONDITIONS OF WATER QUALITY (HARDWATER) AND IN THE LEAST ADEQUATE SITES.**
SISTEMA DE PALETAS QUE PERMITE FABRICAR HIELO EN LAS CONDICIONES MÁS ADVERSAS DE CALIDAD DE AGUA (AGUA DURA) Y EN LOS EMPLAZAMIENTOS MENOS ADECUADOS.
- ▶ **PADDLE SYSTEM THAT MAKES WATER FILTERS UNNECESSARY, AVOIDING THEIR COSTS.**
SISTEMA DE PALETAS QUE HACE INNECESARIOS LOS FILTROS DE AGUA, EVITANDO SUS COSTES.
- ▶ **WATER MOVEMENT THANKS TO PADDLES GRANTS THAT THE PUREST WATER TOUCHES THE EVAPORATOR AND GET FROZEN, OBTAINING THE CLEAREST ICE CUBE.**
EL MOVIMIENTO DEL AGUA GRACIAS A LAS PALETAS GARANTIZA QUE EL AGUA MÁS PURA TOQUE EL EVAPORADOR, OBTENIENDO EL CUBITO MÁS CLARO.
- ▶ **DESIGNED WITHOUT THERMOSTAT, AVOIDING PROBLEMS & GETTING ALL ICE IS POSSIBLE.**
DISEÑADA SIN TERMOSTAT, SE EVITAN PROBLEMAS Y SE OBTIENE TODO EL HIELO POSIBLE.
- ▶ **WITHOUT TIMER. DETECTION OF END OF CYCLE AND FULL BIN ARE DETECTED THROUGH MECHANICAL DEVICES.**
SIN TEMPORIZADOR, SE DETECTA EL FINAL DEL CICLO DE HIELO Y EL LLENADO DEL ALMACEN A TRAVÉS DE DISPOSITIVOS MECÁNICOS.
- ▶ **SIMPLE AND RELIABLE MANUFACTURING DESIGN.**
DISEÑO DE FABRICACIÓN SENCILLO Y FIABLE.
- ▶ **PRODUCES A SEMI-HOLLOW CUBE WITH A GREATER SURFACE THAT COOLS FASTER THE DRINK.**
PRODUCE UN CUBITO SEMIHUECO CON UNA MAYOR SUPERFICIE QUE ENFRÍA MÁS RÁPIDO LA BEBIDA.
- ▶ **DOOR-OPENING MOVEMENT DAMPENING SYSTEM TO AVOID ACCIDENTS.**
APERTURA DE PUERTA HACIA DENTRO PARA EVITAR ACCIDENTES.
- ▶ **ON/OFF LIGHTED ROCKER SWITCH IN FRONT PANEL.**
INTERRUPTOR LUMINOSO DE FUNCIONAMIENTO ON/OFF EN EL PANEL FRONTAL.
- ▶ **AISI 304 STAINLESS STEEL FRAME.**
CARROCERÍA EN ACERO INOXIDABLE AISI 304.
- ▶ **TROPICALIZED MACHINES (T CLASS).**
MÁQUINAS TROPICALIZADAS (CLASE T).



	 24 H	 10°C (Kg)	 10°C (Kg)	 21°C (Kg)	 15°C (Kg)	 STOCK (Kg)	 (mm)	 (mm)	
PS 122 A		111	108	50	Width 843 Depth 557 Height 984*	Width 925 Depth 637 Height 1.125			
PS 122 W		128	115		Height 984*	Height 1.125			

PS 20gr
29 (Ø) x 42 mm (H)
Average dimensions Dimensiones promedio

* WITH LEGS 1.089/1.139 CON PATAS 1.089/1.139

ACCESSORIES ACCESORIOS

INCLUDED



WATER INLET HOSE
MANGUERA DE ENTRADA DE AGUA



WATER OUTLET HOSE
MANGUERA DE DESAGÜE



4 HEIGHT ADJUSTABLE LEG KIT
KIT 4 PATAS ALTURA REGULABLE



WATER INLET FILTER GASKET
JUNTA DE FILTRO DE ENTRADA DE AGUA



MEDIUM SCOOP
PALA MEDIANA

NOT INCLUDED (OPTIONAL)



ANTI-LIMESCALE FILTER
FILTRO ANTICAL



C4 WATER SOFTENER
DESCALCIFICADOR C4



ANTI-LIMESCALE + ANTI-CHLORINE FILTER CS101
FILTRO ANTICAL + ANTICLORO CS101



CALKLIN 50 CLEANER
PRODUCTO ANTICAL



PARTICLE FILTER
FILTRO ANTIPARTÍCULAS



ANTI-CHLORINE FILTER
FILTRO ANTICLORO



4 WHEELS KIT
KIT 4 RUEDAS

RIGHT SIDE VIEW
VISTA LATERAL DERECHA



FRONTAL VIEW
VISTA FRONTAL

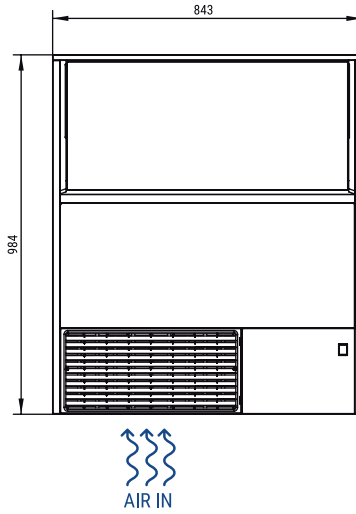

REAR VIEW
VISTA TRASERA

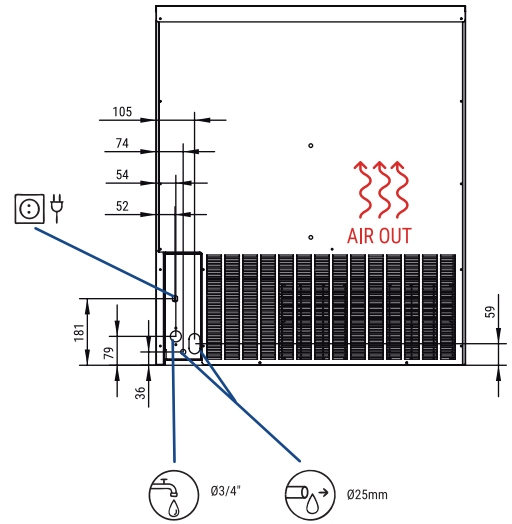

* All measurements in mm.
* Todas las cotas en mm.

OPERATING CONDITIONS CONDICIONES DE OPERACIÓN

PRODUCTION 50Hz PRODUCCIÓN 50 Hz

±10% V

5°C/43°C

5°C/35°C

1 bar/6 bar

80 Ice cubes/cycle

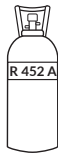

V	Hz	ph
230	50	1N

PS 122 AIR COOLED

	°C			
	10°	15°	21°	30°
°F	50°	60°	70°	86°
10°	111	106	93	75
50°	112	108	95	76
21°	90	86	77	50
68°	61	57	43	20
32°				
90°				
43°				
109°				

PS 122 WATER COOLED

	°C			
	10°	15°	21°	30°
°F	50°	60°	70°	86°
10°	128	119	110	96
50°	123	115	108	95
21°	120	112	106	92
68°	117	109	105	90
32°				
90°				
43°				
109°				

MODELS
MODELOS

PS 22 A

PS 122 W

	+c° -c°	ASHRAE CONDITIONS CONDICIONES ASHRAE (W) (BTu/h)	(W) 43°C	(n.) (mm ²)	FUSE	100 Kg (Kwh)	(l/h)	HEAT REJECTED (W) (BTu/h)	(Kg)	(Kg)	(m ³)
PS 22 A		2.075 7.080	890	2 1,5	10	15	12,2	1.519 5.183	80	86	0,66
PS 122 W		2.075 7.080	637	2 1,5	10	12	61,8	1.519 5.183	80	86	0,66