

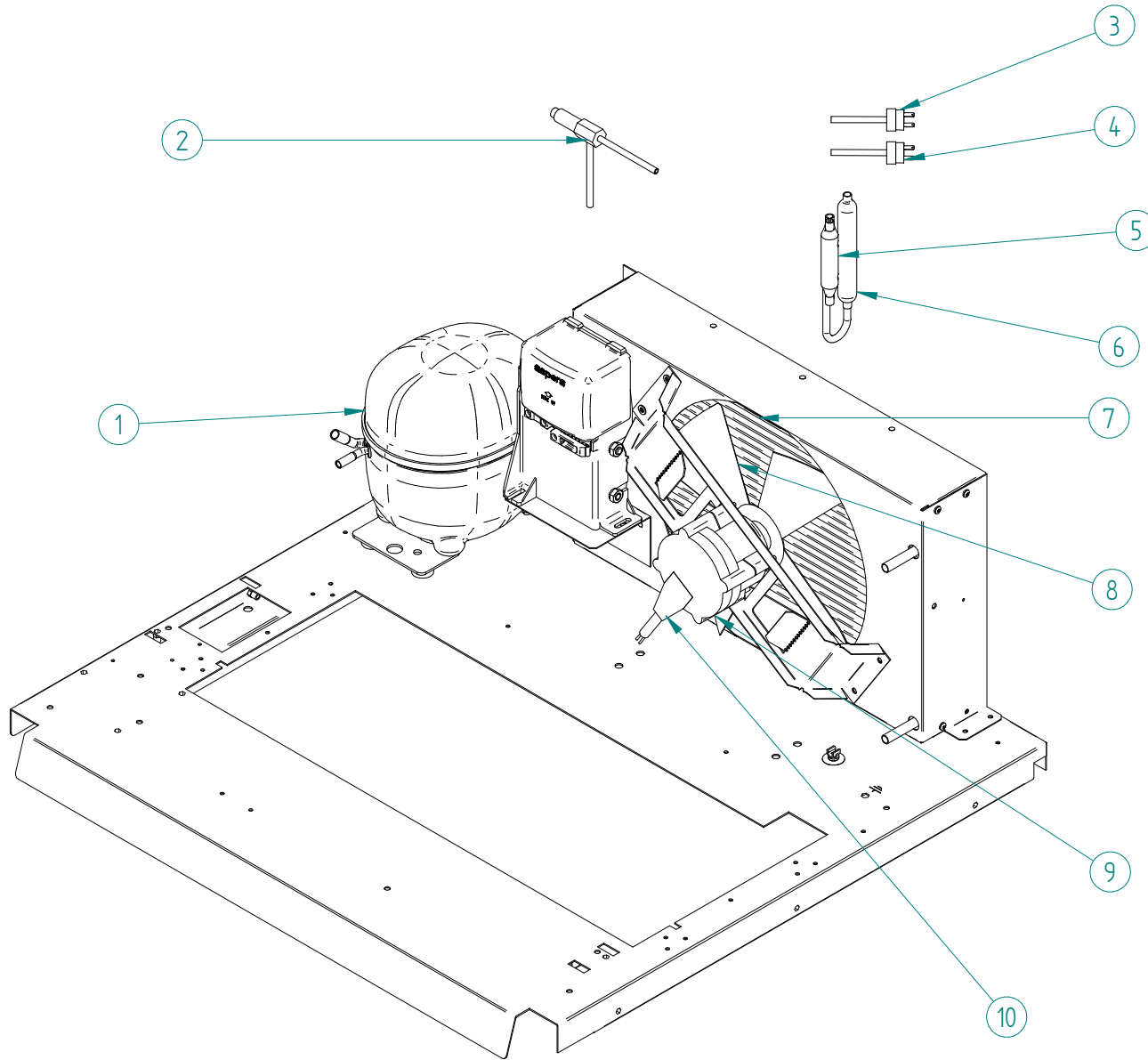

DESPIECE / REPUESTOS  
EXPLODED VIEW / SPARE PARTS  
EXPLOSIONSZEICHNUNG / ERSATZTEILE  
VUE ÉCLATÉE / PIÈCES DÉTACHÉES  
ESPLOSO / RICAMBI

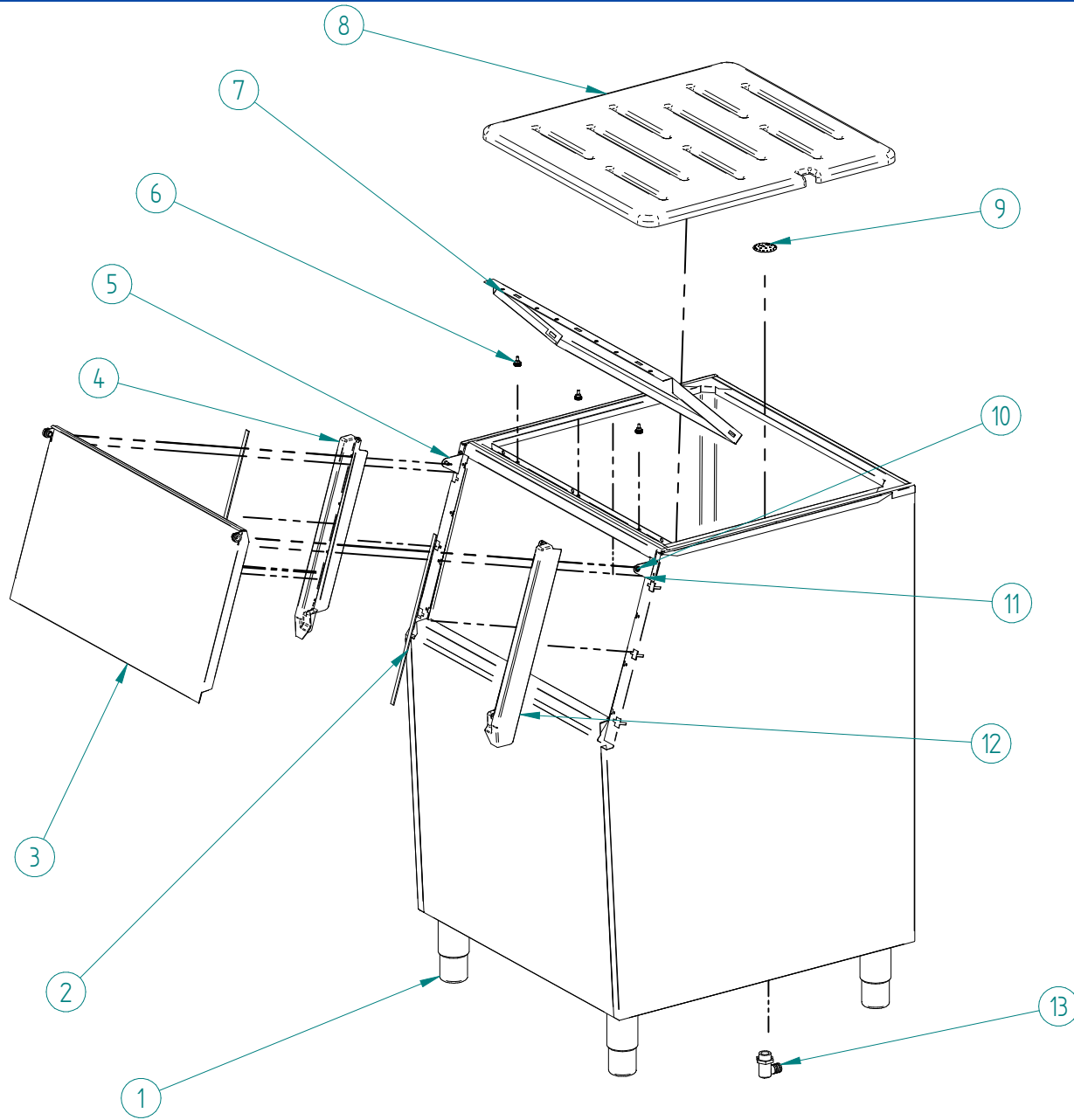

ITEM	DESCRIPTION	CODE
1	COMPRESSOR	31307
2	HOT GAS VALVE - BODY	1473
3	FAN CONTROL PRESSURE SWITCH	31160E
4	HIGH PRESSURE SWITCH	31660E
5	PRESSURE SWITCH COLLECTOR	31444
6	FILTER DRIER	7896
7	AIR CONDENSER	34091
8	FAN BLADE	8609
9	FAN MOTOR	32654A
10	HOT GAS VALVE - BODY	1473



ITEM	DESCRIPTION	CODE
1	BIN LEG	6749
2	SILICONE PROTECTOR	6815
3	BLACK BIN DOOR	31038
4	LEFT DOOR GUIDE	6644
5	LEFT HINGE	6740
6	KNURLED SCREW	6796
7	BIN DEFLECTOR	6745
8	OVERFLOOR	30086
9	BIN DRAIN	766
10	SCREW M-6X12	6753
11	RIGHT HINGE	6739
12	RIGHT DOOR GUIDE	6643
13	DRAIN FITTING	3683

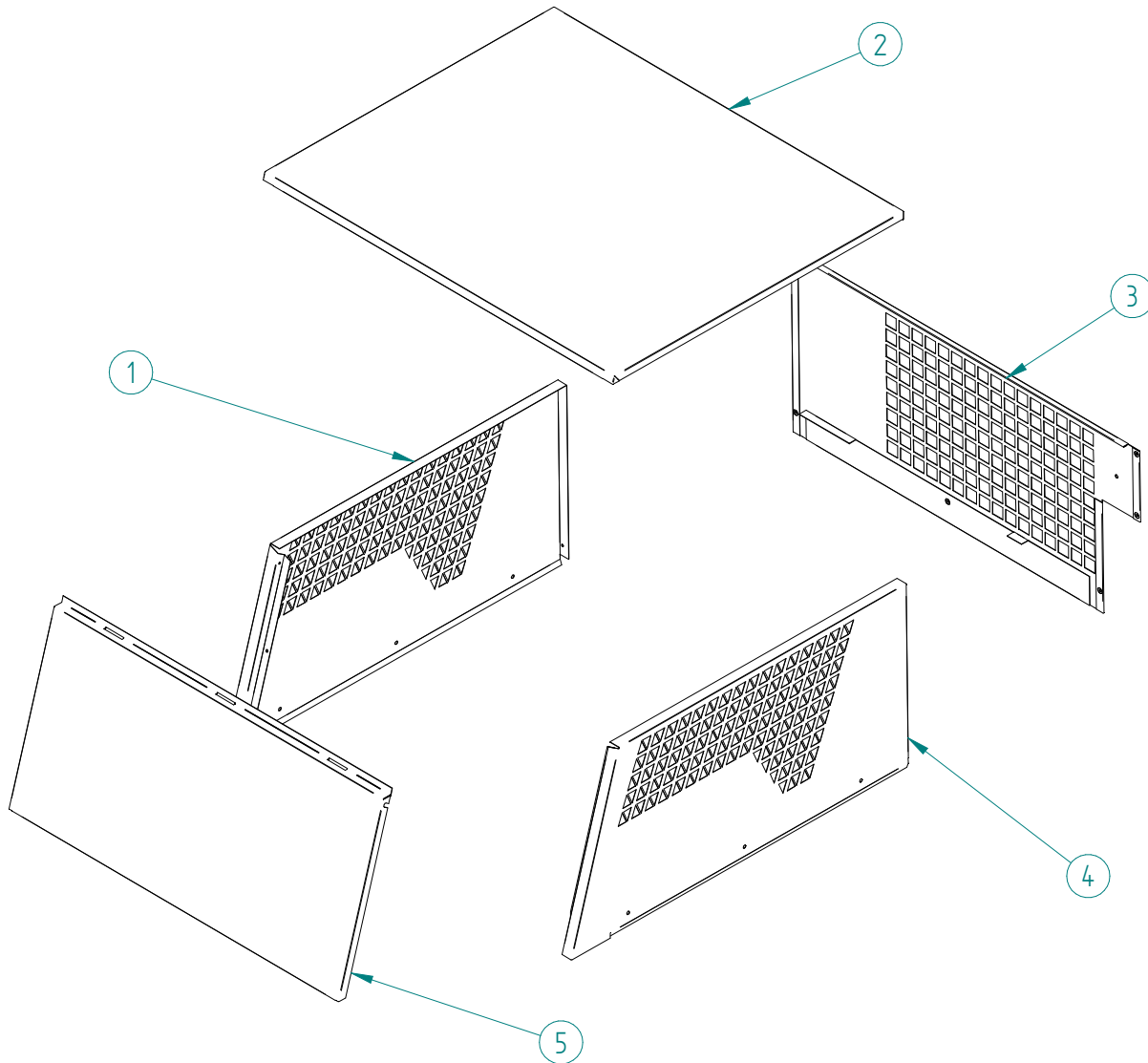

ITEM	DESCRIPCION	CODE
1	LEFT PANEL	8898
2	TOP PANEL	8901
3	REAR COVER	8900U
4	RIGHT PANEL	8897
5	FRONT PANEL	8899

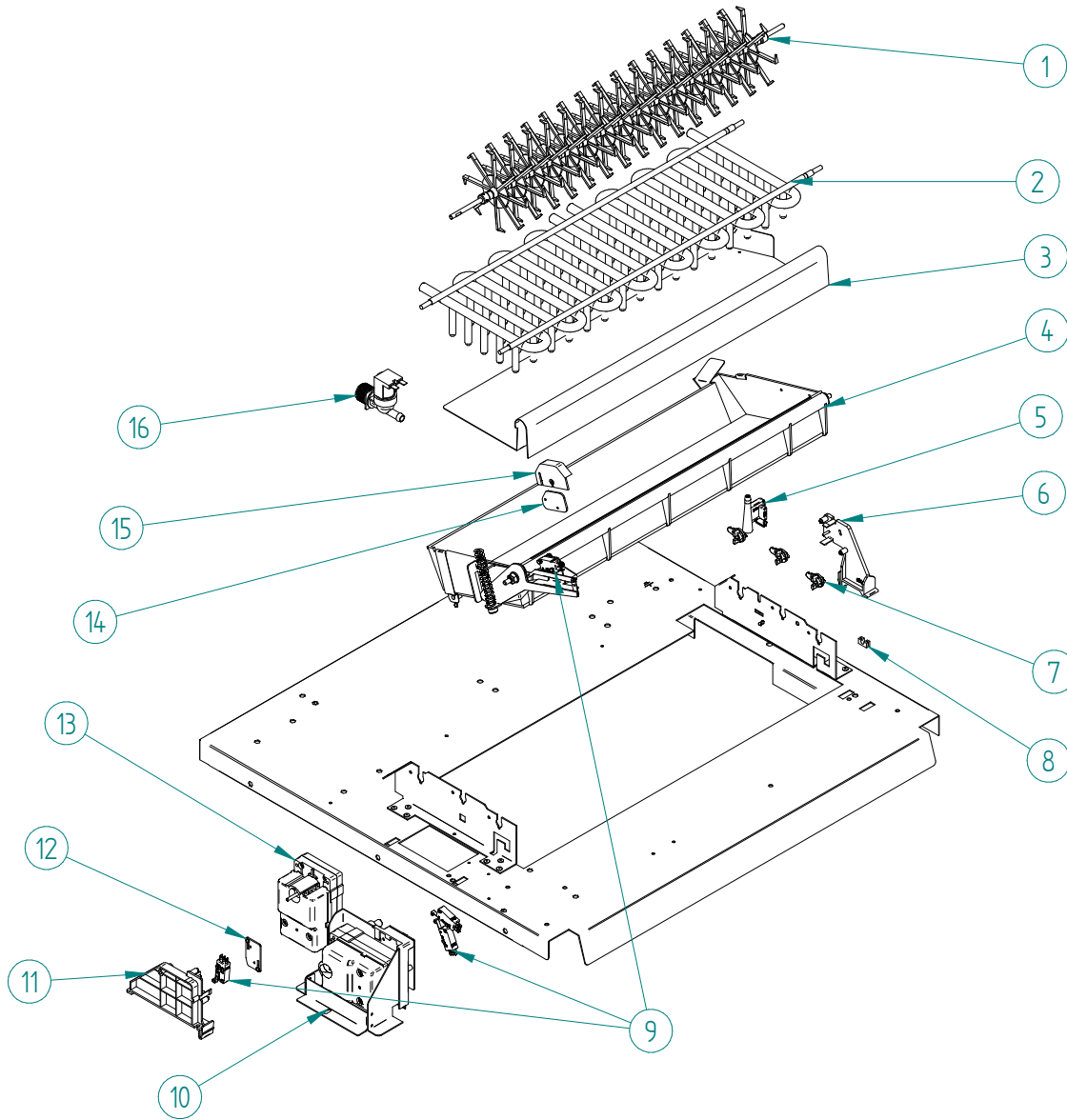

ITEM	DESCRIPTION	CODE
1	PADDLE	8546
2	EVAPORATOR	8032
3	WATER TRAY	5273
4	ICE DEFLECTOR COMPLETE	5530
5	WATER INLET	6843
6	WATER LEVEL SUPPORT	6845
7	EVAPORATOR SUPPORT	6841
8	NYLON TRAY BEARING	168
9	ATEX MICRO SWITCH	32998
10	COMPLETE TURNING MOTOR	5200U
11	PADDLE MOTOR BRACKET	6848
12	AGITATOR MICRO COVER	6849
13	SHAKER MOTOR	6837
14	MICRO SWITCH PROTECTION	5211
15	MICRO SWITCH BOX	372
16	WATER VALVE	329

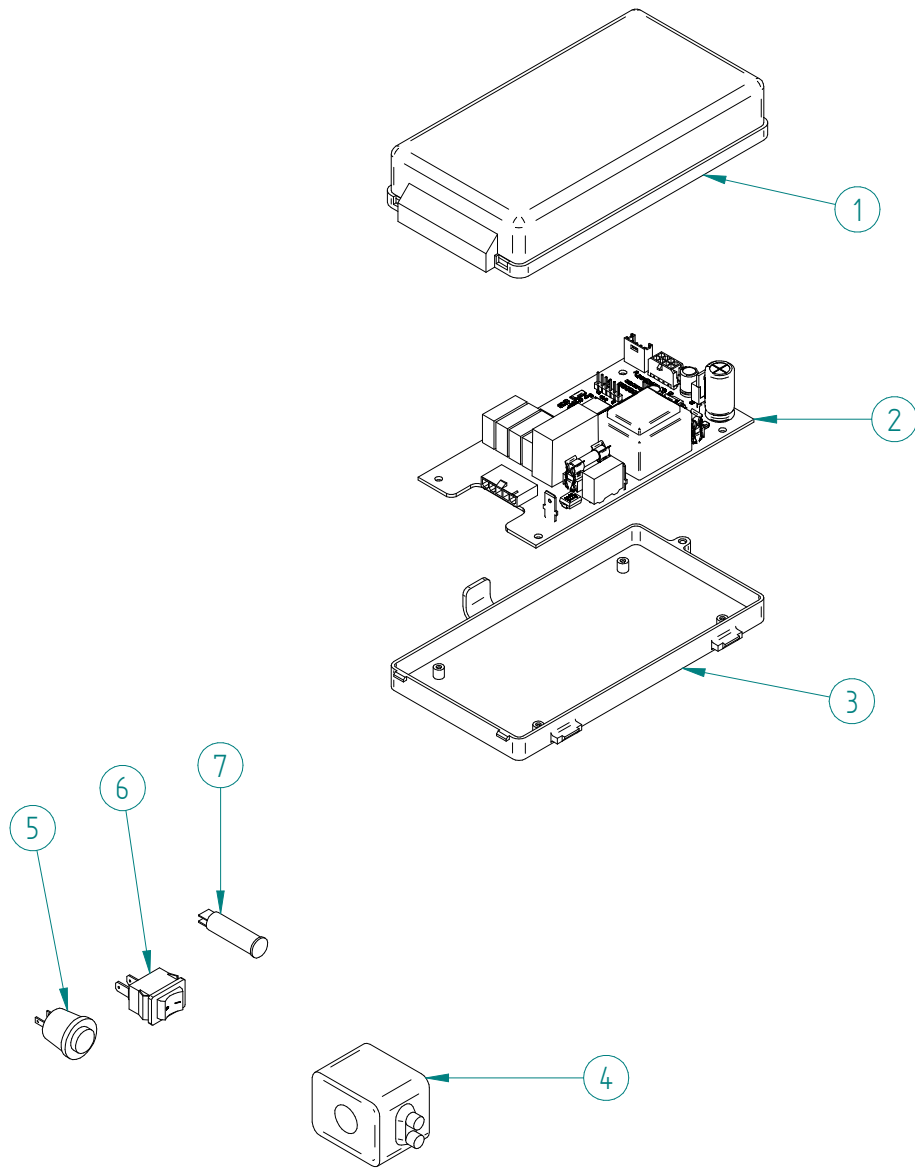

ITEM	DESCRIPTION	CODE
1	ELECTRIC BOX COVER	2182
2	ELECTRONIC BOARD	32715
3	ELECTRIC BOX	2181
4	HOT GAS VALVE - COIL	5173
5	CLEANING SWITCH	31719
6	MAIN SWITCH	32416
7	LED	32415