



INSTALLATION MANUAL

SC 3000 COMPACT

ADVICE FOR THE INSTALLATION OF SC 3000 COMPACT

STEP 1: LOCATION OF THE ICE MACHINE

- Needs an electricity connection: 1 three phase socket 5+TTx6 mm². Install differential and thermal in the main frame (32 amps, consumption 14870W).
- Water supply: needs a nearby tap for water inlet. ¾".
- Outlet: The unit has an overflow tube, to prevent water from entering the evaporator drum, in the event of failure of the filling buoy. Needs to have an outlet drain nearby. The drain pipes of the unit should not be siphoned at any time, the water should drain without problems. In addition, there is a shut-off valve with tap for emptying the water tank. 21 mm diameter or 38 mm diameter depending on the unit.

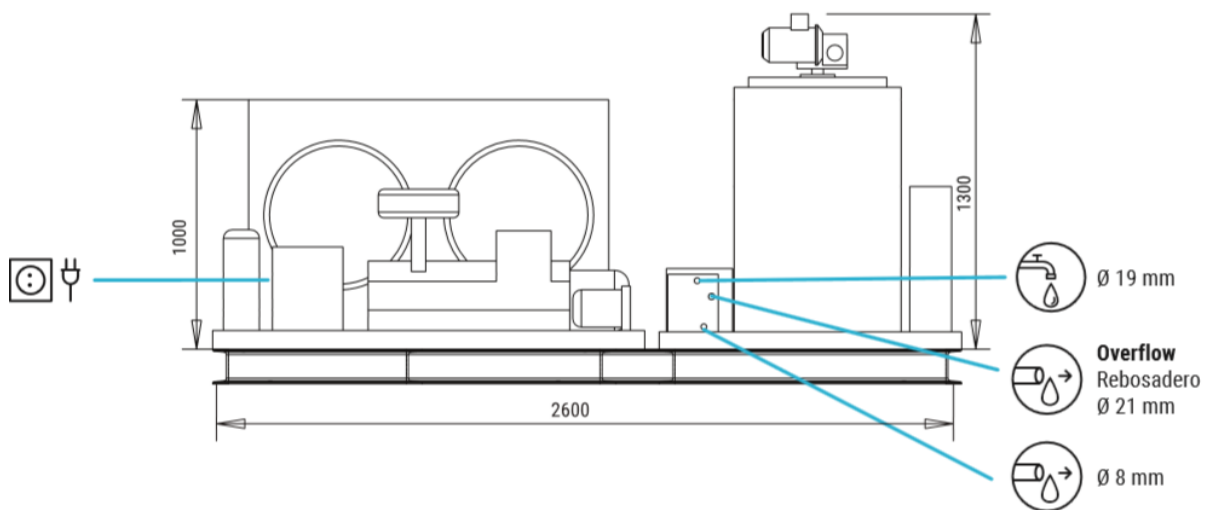

- The machinery must be hoisted with care not to move the gear motor on the evaporator. Use a lift or crane with straps using the unit's base.
- Keep in mind that the air enters through the condenser front and exits to the area of the compressor. Have good ventilation in the location of the unit.
- Level the unit correctly.

	Minimum value	Maximum value
Room temperature	5°	40°
Water temperature	5°	35°
Water pressure	1 bar	5 bar
Voltage variation	-10%	6%

Step 2: INSTALLATION REMOTE ELECTRICAL CONTROL BOX (TO BE INSTALLED IN SILO CHAMBER)

The remote box lets you control the unit from the silo chamber. It has a switch to start/stop the ice maker, and another to start/stop the water evaporator (cooler). In addition, it has LEDs indicating:

- Reducer gear
- Full of ice
- Cooler gear
- Thermal reducer failure
- Thermal compressor failure
- Lack of water



Remote box

For the connection, a signal cable is required, 12x1 mm². The cable is connected to the terminal board of the remote panel, and from there to the terminal board in the box of the condenser unit of the generator (12 terminals).



Terminal box condenser unit generator

In addition, there are two outputs to power the cooler (evaporator), which is located in the chamber, upper part, to cool the water that goes to the generator. Use a 3x1.5 mm² cable to feed.

REMOTE CONTROL SC 3000

- 1. Phase L
- 2. Phase N
- 3. Reduction gear
- 4. Reduction gear
- 5. Full ice photocell
- 6. Full ice photocell
- 7. Thermal reducer
- 8. Thermal compressor
- 9. Lack of water
- 10. Lack of water
- 11. Stop/start generator
- 12. Stop/start generator
- 13. Cooler
- 14. Cooler
- Q. Circuit breaker 10A

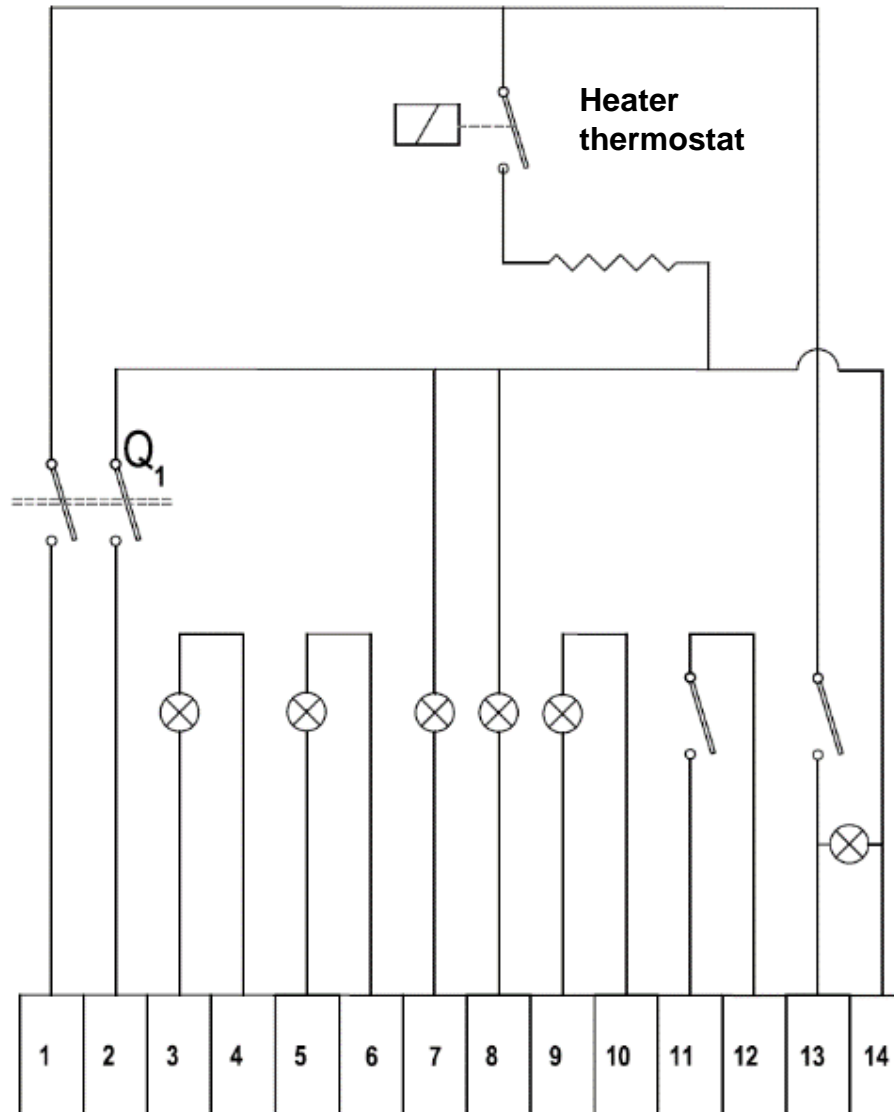

STEP 3: PLUMBING INSTALLATION

The ice generator has a $\frac{3}{4}$ " water inlet, ready to connect the water supply network. In the installation is included a cooler (evaporator) to be placed in the silo chamber, and to reduce the inlet temperature of water to the unit. This cooler has only one fan that is connected to the start/stop of the remote panel.

To install the cooler, we recommend making a bypass system to be able to cancel it if necessary.

Below we show photos of an installation for two SC 3000 units.



Mounting pipes with bypass in covered shed



Cooler housing

The water tank has an upper overflow pipe, to avoid possible overflow of water (float valve), as well as a key in the lower part for emptying the water tank. It is advisable to install a drain for the overflow and the drainage outlet for the tank.

Keep in mind that the unit always uses the water in the tank to produce, and in normal operation, does not lose water.

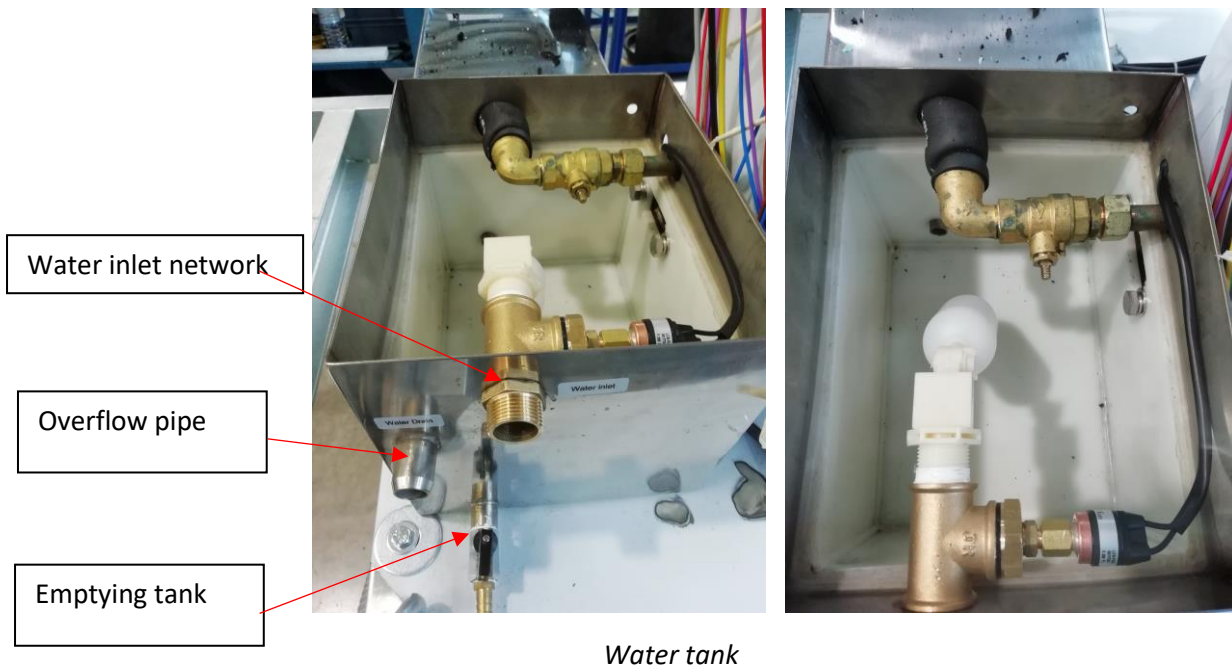

STEP 3: INSTALLATION OF PIPE FOR ICE DROPPING TO SILO

The ice comes out through the circular opening of the evaporator and falls by gravity. Being sub-cooled flake ice, from -5°C to -7°C , with a thickness of 1.2 mm to 3 mm, it inclines to come out (by the rotation of the milling cutter that causes the ice to fall from the evaporator wall). You have to make a drop to drive the ice into the box.

It is usually a hopper outlet and then flow into the silo. It can be in stainless or food PVC.

The drop must have an adequate slope, so do not make an exit of more than 30% to prevent the ice from caking.

Below are photographs taken in a stainless installation.



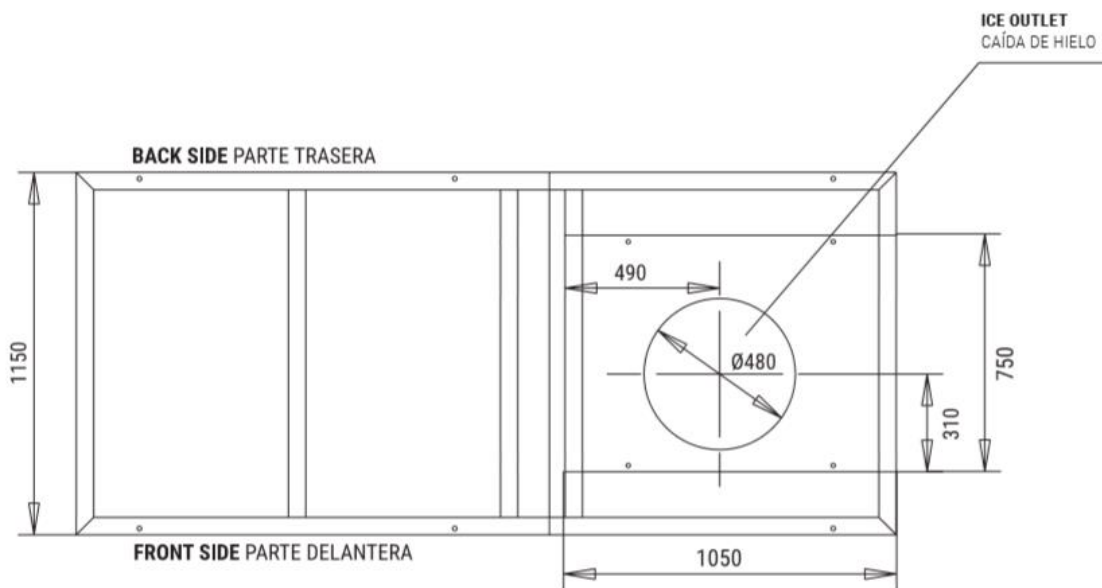

Bottom of ice unit

STEP 4: INSTALLATION STOP PHOTOCELL

The unit has a remote stop photocell, which can be installed in the chamber, to stop the ice falling (if the fall is completely conducted, it is not necessary, since it stops just below the evaporator, which has the stop photocell for full of ice).

Here is how the photocell connects. A 5x1 mm² hose is needed to feed the photocell and the signal, from the location of the photocell to the electrical panel of the ice generator.

External stop kit (c.5275)



Selector position

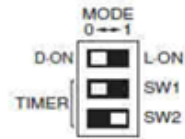

Position D – On

SW1 position 0 (left)

SW2 position 1 (right)

Position the switch as indicated in the figure

- Adjust the TIME selector to the minimum until it stops in anti-clockwise rotation
- Adjust the operating distance with the SENS selector
- Put an object at the desired distance

If the sensor does not detect the object (LED ON)

- Turn the SENS selector clockwise until the LED light goes off
- Turn the SENS selector slightly counterclockwise until the LED lights up

If the sensor detects the object (LED OFF)

- Turn the SENS selector counterclockwise until the LED lights up
- Remove the object

Adjust the TIME selector two stripes clockwise past the MIN

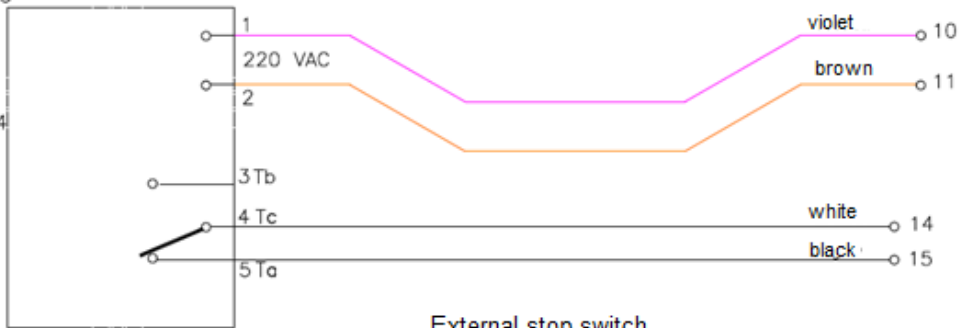

connect remote photocell

remove bridge and connect white wire to "14" and black to "15"

Photocell
Omron E3JM-DS70M4T-G
(C.30991)

External stop switch
(C.1970)

STEP 5: STARTING UP

- Start the unit. It comes with a control panel, with a delayed start of 3 minutes for safety. After 3 minutes, the water pump starts up, the reduction motor starts and the liquid solenoid valve opens, then the unit starts.
- The evaporator panel comes with a speed variator, which allows modifying the frequency of rotation of the motor, allowing speeds below 50Hz (factory parameter) achieving thicknesses greater than 1.5 mm and up to 3 mm. The production loss is not more than 20% at a speed of about 30 Hz. We do not advise lowering more than 30 Hz.
- The variable speed drive also has the function of heat gear motor. It is responsible for stopping the same in case of overloading of the engine.

ELECTRIC DIAGRAM EVAPORATOR PANEL UNIT

