



SC 400 CO₂ SPLIT









MODULAR FLAKE ICE MACHINE SPLIT

230 V / 50 Hz

FEATURES CARATTERISTICHE

- ▶ **PRODUCES COLD AND DRY FLAT FLAKES. FLAKE THICKNESS MAY BE ADJUSTED BETWEEN 1.5 mm AND 3 mm.**
 PRODUCE SCAGLIE PIANE MOLTO FREDDI E ASCIUTTE. LO SPESSORE È REGOLABILE DA 1.5 A 3 mm.
- ▶ **BASED ON A STATIC CYLINDER WHICH IS FREE FROM SWIVEL JOINTS (HELICAL REAMER) COUPLED WITH A MILLING TOOL THAT DETACHES THE ICE WITHOUT ANY STRAINED OR FORCED MOVEMENTS.**
 FUNZIONAMENTO BASATO SU UN CILINDRO STATICO SENZA GIUNTI ROTANTI (ALESATORE ELICOIDALE) E CON UNA FRESA CHE STACCA IL GHIACCIO SENZA TENSIONE O SFORZO.
- ▶ **THE MOST EFFICIENT EVAPORATOR OF THE MARKET, LESS ENERGY CONSUMPTION AND HIGHER ICE PRODUCTION.**
 L'EVAPORATORE PIÙ EFFICIENTE SUL MERCATO, CONSUMO ENERGETICO MINORE, MAGGIORE PRODUZIONE DI GHIACCIO.
- ▶ **ELECTRONIC STOP SYSTEM / ELECTRICAL CONTROL PANEL / DRIVE DIRECT GEAR MOTOR / MAGNETIC DRIVE PUMP / LOW WATER SAFETY DEVICE.**
 SISTEMA ELETTRONICO DI ARRESTO / PANNELLO DI CONTROLLO ELETTRICO / MOTORIDUTTORE CON TRASMISSIONE DIRETTA / POMPA A TRASCINAMENTO MAGNETICO / DISPOSITIVO DI SICUREZZA IN CASO DI MANCANZA DI ACQUA.
- ▶ **STAINLESS STEEL SOLEPLATE.**
 PIASTRA IN ACCIAIO INOSSIDABILE.
- ▶ **CONTROLLERS TO DETECT: LOW WATER LEVEL, TEMPERATURE RISE DUE TO MOTOR OVERLOAD OR FULL VAT.**
 DISPOSITIVI PER RILEVARE: MANCANZA DI ACQUA, AUMENTO DELLA TEMPERATURA A CAUSA DEL SOVRACCARICO DEL MOTORE O PER RIEMPIMENTO DELLA VASCHETTA.
- ▶ **ELECTRONIC EXPANSION VALVE / SUCTION REGULATING VALVE / STOP WHEN FULL BIN STOP WITH PHOTOELECTRICAL SENSOR.**
 VALVOLA AD ESPANSIONE ELETTRONICA / VALVOLA DI REGOLAZIONE DELL'ASPIRAZIONE / ARRESTO PER RIEMPIMENTO DELLA VASCHETTA CON CELLULA FOTOELETTRICA.

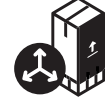

	 24 H	 10°C	 10°C	 21°C	 15°C	 (mm)	 (mm)	
SC 400 CO ₂ SPLIT 	450	400	Width 1.090 Depth 700 Height 760	Width 1.220 Depth 820 Height 915	FLAKE ICE -7°C Ice Temperature			

ACCESSORIES ACCESSORI

INCLUDED



WATER INLET FILTER GASKET
GIUNTA DEL FILTRO DI INGRESSO DELL'ACQUA



WATER INLET HOSE
TUBO INGRESSO DELL'ACQUA



WATER OUTLET HOSE
TUBO DI SCARICO

NOT INCLUDED (OPTIONAL)



ICE DROP CHUTE
TUBO DI FUORIUSCITA DEL GHIACCIO



SALT DOSING PUMP WITH TANK
BOMBA DOSATORE DI SALE CON SERBATOIO



REMOTE SWITCH
INTERRUTTORE REMOTO



REMOTE SWITCH & WEEKLY PROGRAMMER
INTERRUTTORE REMOTO CON TIMER SETTIMANALE



EXTERNAL STOP FULL BIN PHOTO CELL
SENSORE DI ARRESTO ESTERNO PER RIEMPIMENTO

RECOMMENDED BINS SERBATOI RACCOMANDATI



B400 + SC 400 CO2 SPLIT



B500 + SC 400 CO2 SPLIT



BCD400 + SC 400 CO2 SPLIT



BCD600 + SC 400 CO2 SPLIT



BCD800 + SC 400 CO2 SPLIT

SC 400 CO₂ SPLIT

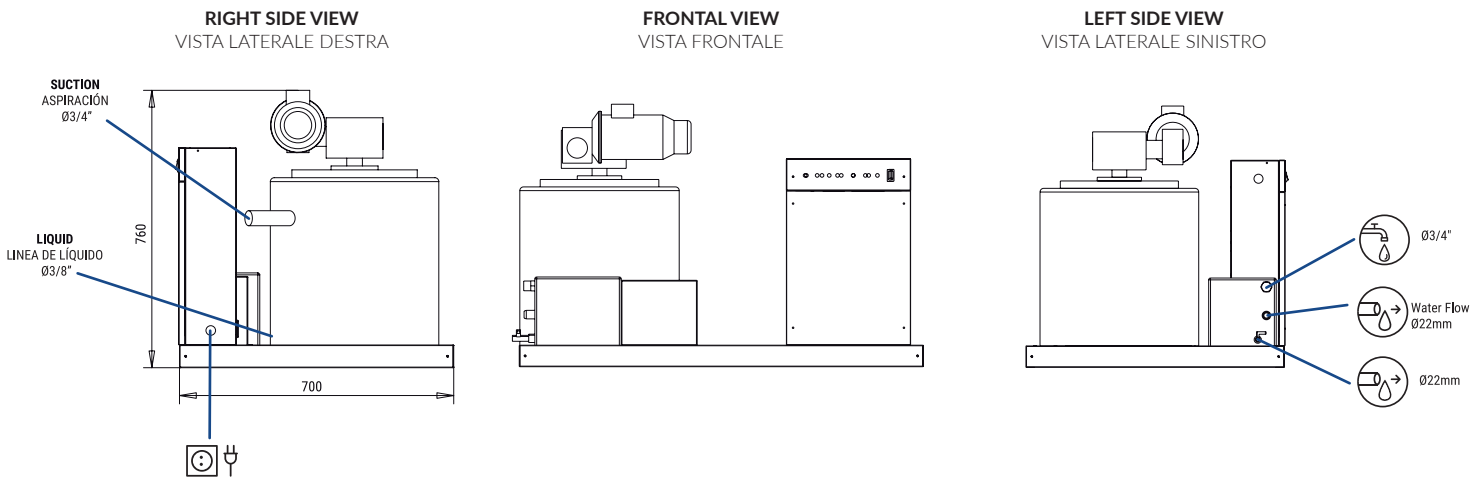

CENTRAL CROSS SECTION VIEW OF THE BASE
VISTA DELLA BASE DALLA ZONA CENTRALE

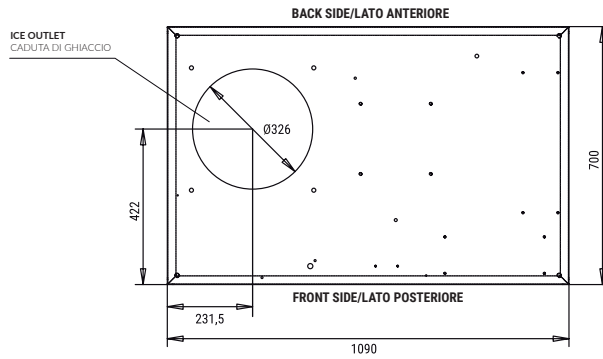

* All measurements in mm.
* Tutte le misure in mm.

OPERATING CONDITIONS CONDIZIONI PER IL FUNZIONAMENTO

PRODUCTION 50Hz PRODUZIONE 50 Hz

V	Hz	ph	SC 400 CO ₂ SPLIT					SC 400 CO ₂ SPLIT				
			10°	15°	21°	30°	10°	15°	21°	30°		
±10% V			450	420	350	310	419	391	326	288		
10°C/43°C			440	400	335	290	409	372	312	270		
5°C/38°C			410	360	300	260	381	335	279	242		
1 bar/6 bar			335	290	230	200	312	270	214	186		

MODELS MODELLI	Temp.EV. (°C)	ASHRAE CONDITIONS CONDIZIONI ASHRAE (W) (BTu/h)	(W) 43°C	(n.) (mm ²)	FUSE	100 Kg (Kw/h)	(l/h)	HEAT REJECTED (W) (BTu/h)	(Kg)	(Kg)	(m ³)
SC 400 CO ₂ SPLIT	-22	2.200 7.507	1.425	3 1,5	16	7,5*	16,6	- -	100	127	0,92

* WHEN INDICATED COOL REQUIREMENT IS SUPPLIED / QUANDO VIENE FORNITA LA POTENZA FRIGORIFERA RICHIESTA.