



SS/SK



DESPIECE / REPUESTOS
EXPLODED VIEW / SPARE PARTS
EXPLOSIONSZEICHNUNG / ERSATZTEILE
VUE ÉCLATÉE / PIÈCES DÉTACHÉES
ESPLOSO / RICAMBI

TECHNICAL ASSISTANCE
 SERVICE

CABINET



SS/SK

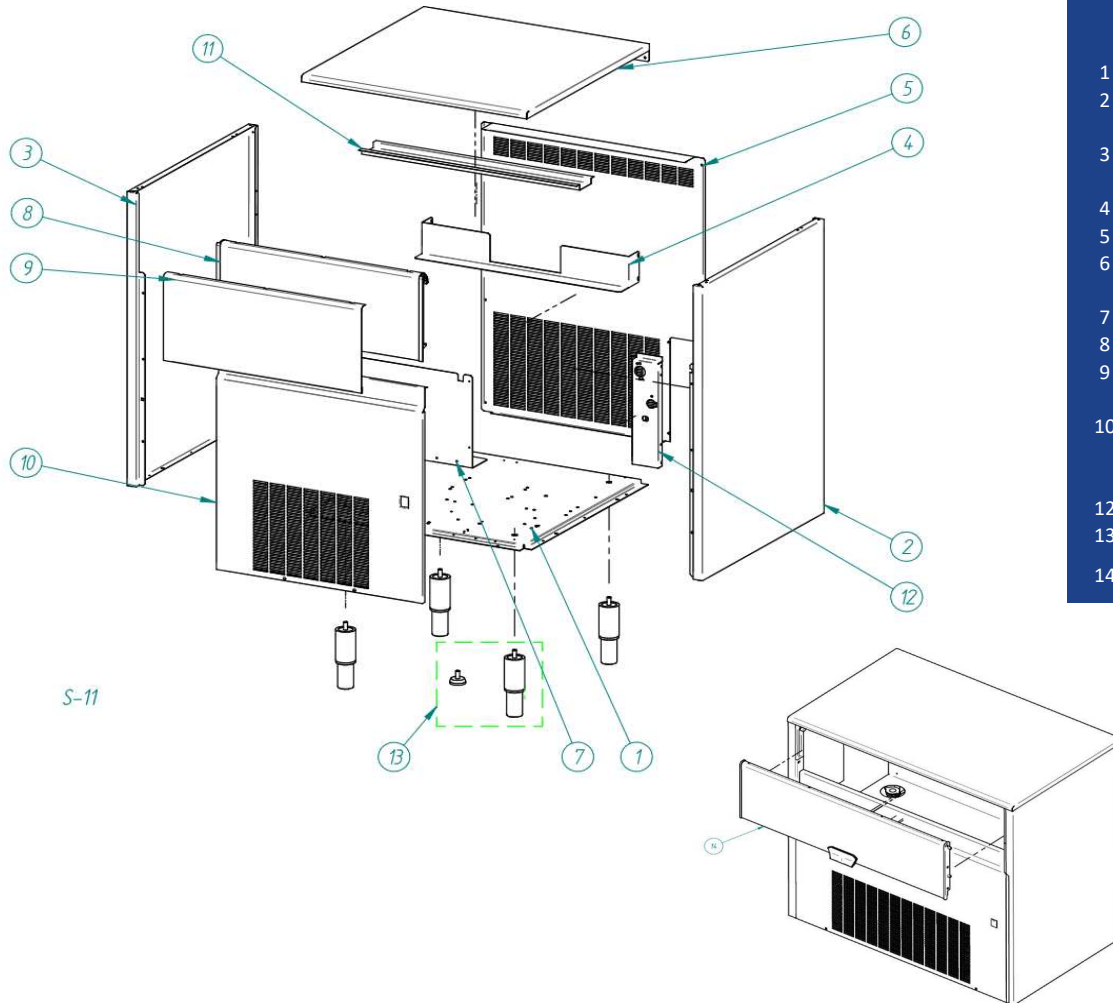

	NAME	MODEL				
		35	45	60	80	135
1	BASE	4101	4116	4116	4143	31012
2	RIGHT PANEL SS	4810	4812	4814	4814	4816
	RIGHT PANEL SK	4436	4438	4440	4440	4442
3	LEFT PANEL SS	4811	4813	4815	4815	4817
	LEFT PANEL SK	4437	4439	4441	4441	4443
4	REAR SUPPORT	4106	4122	4136	-	-
5	REAR PANEL	4108	4124	4138	4138	4460
6	TOP PANEL SS	4818V1	4819V1	4820V1	4820V1	4821V1
	TOP PANEL SK	4444V1	4445V1	4446V1	4446V1	4447V1
7	FRONT SUPPORT	4105	4121	-	-	-
8	DOOR	4268	4269	4270	4270	4271
9	TOP PANEL (DOOR) SS	6418	4831	4832	4832	4833
	TOP PANEL (DOOR) SK	4456	4457	-	-	-
10	FRONT PANEL AND GRILL SS	2086	2088	2089	2089	6453
	FRONT PANEL AND GRILL SK	4448	4449	4450	4450	4451
	TOP PANEL REINFORCEMENT	30170	30171	30172	30172	4847
12	TUBE SUPPORT	4107	4123	4137	4137	4298
13	LEGS	1478				
14	SS 135 door since s/n 17950794					31146
	SK 135 door since s/n 17950794					31110

BIN & HIDRAULICS PARTS

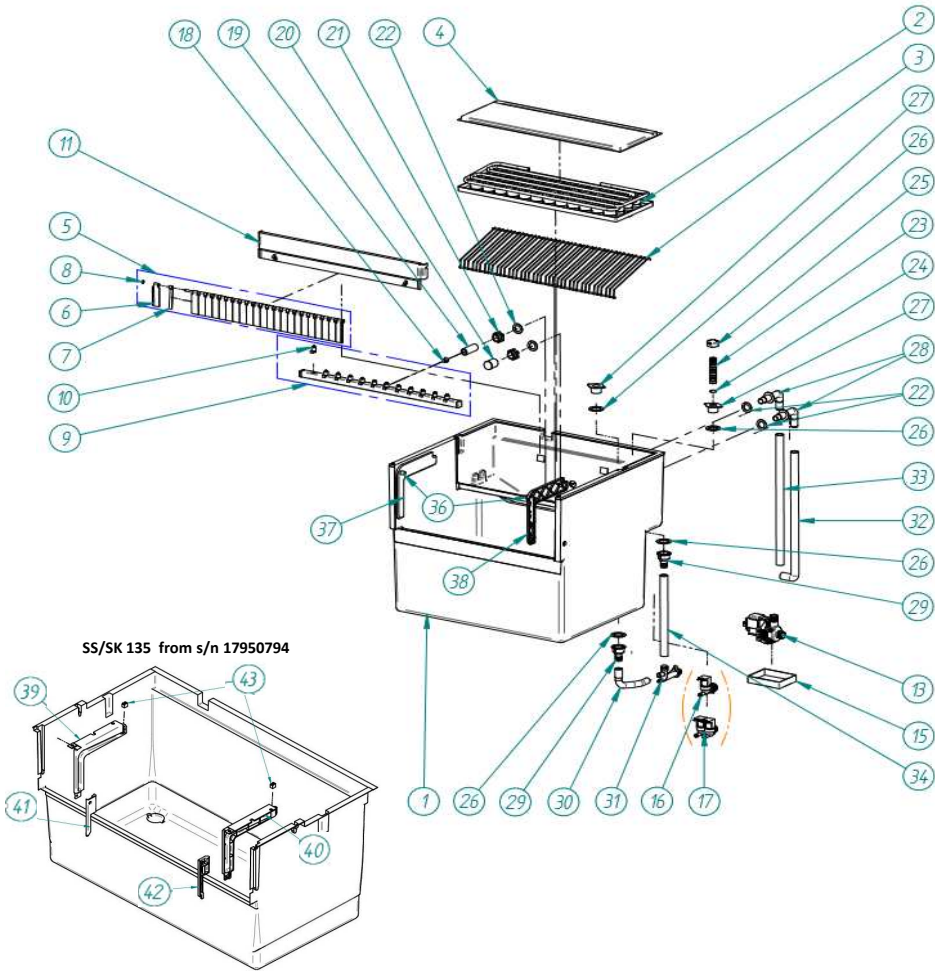

	NAME	MODEL				
		35	45	60	80	135
1	STOCK BIN	7460	7461	7462	7498	
2	EVAPORATOR	30 gr	7449	7450	7451	7501
		40 gr	7435	7440	7441	7469
3	EJECT CUBE GRILL	8904	8905	8906	8907	
4	EVAPORATOR COVER	4707	4708	4709	4710	
5	CURTAIN	8362	8363	8364	5957	
6	EXTERIOR CURTAIN SLAT		1213			
7	INTERIOR CURTAIN SLAT		1212			
8	JOINT		107			
9	COLLECTOR	7454	7455	7456	7497	
10	NOZZLE		526			
11	CURTAIN SUPPORT	8176	8177	8178	4298	
13	PUMP	220V/50H	4769		8687K	
		220V/60HZ	32048		8688K	
		115V/60HZ	32049		8689K	
14	PUMP SUPPORT		4613			
15	CONDENSATION TRAY		4521			
16	WATER INLET VALVE	220V/50HZ	1673	6980+4523	1673	7690
		220V/60HZ		1673		6981
		115V/60HZ		4899		
17	WATER INLET VALVE water cond.	220V/50HZ	1674	7691	1674	1913+4476+4527
		220V/50HZ	805	-	-	-
18	WATER REGULATOR	220V/60HZ	32003	-	805	4527
		115V/60HZ	32003	-	-	-
19	TUBE		4098			
20	FILTER		4505			
21	PLASTIC NUT		4502			
22	JOINT		4503			
23	OVERFLOW PLASTIC COUPLING		4426			
24	OVERFLOW TUBE		4496			
25	ELBOW ADAPTER		4427			
26	JOINT		4755			
27	DRAIN		6017			
28	DRAIN ELBOW ADAPTER		4501			
29	DRAIN STRIGHT UNION		6018			
30	DRAIN COUPLING		6021			
31	WATER DISTRIBUTOR		363			
32	WATER INLET TUBE	8829	8830	8831		
33	WATER OUTLET PIPE	4713	4724	4727		
34	OVERFLOW TUBE	4714	4726	4729		
36	CLIP		4276			
37	LEFT GUIDE		4273			
38	RIGHT GUIDE		4272			
39	TOP LEFT GUIDE SS/SK 135 from s/n 17950794				30667	
40	TOP RIGHT GUIDE SS/SK 135 from s/n 17950794				30668	
41	BOTTOM LEFT GUIDE SS/SK 135 from s/n 17950794				30669	
42	BOTTOM RIGHT GUIDE SS/SK 135 from s/n 17950794				30670	
43	DOOR BLOCK SS/SK 135 from s/n 17950794				1715	

AIR CONDENSER

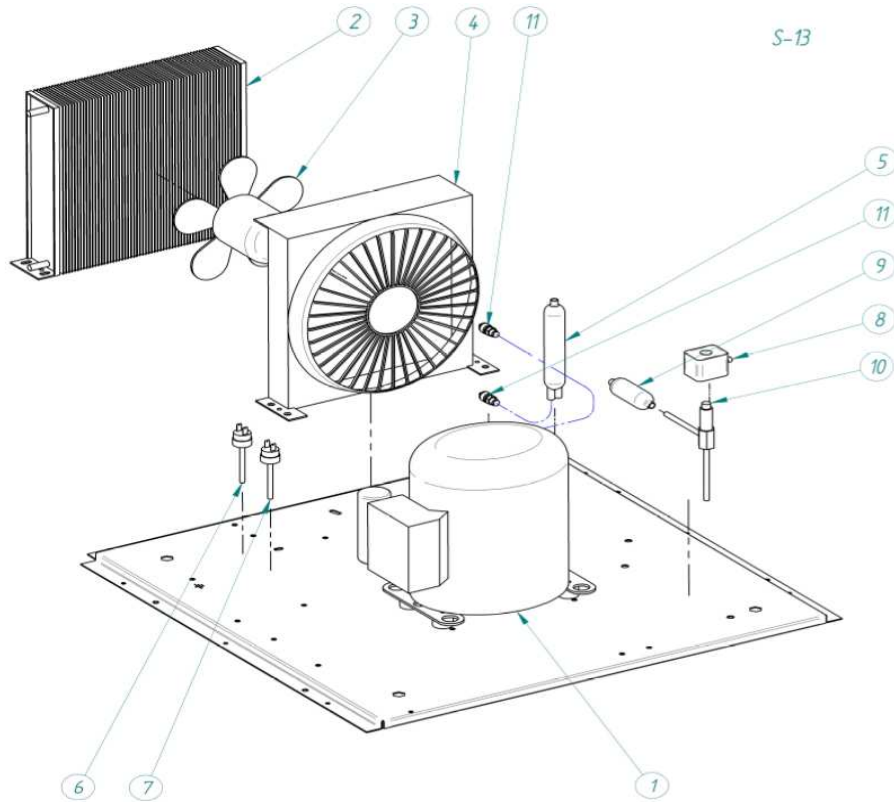

		DESCRIPCION					
		35	45	60	80	135	
1	COMPRESSOR	220V/50HZ	6005	6515		6007	6763
		220V/60HZ	31092	81093	81098		32028
		115V/60HZ	82801	82701	82803		32028
2	CONDENSER		8327		4157	32731	
	FAN	220V/50HZ	2170	28	410	4230	410
3A		220V/60HZ	2170	28	4230		445
		115V/60HZ	2163	4890		4891	
3B	FAN BLADE	220V/50HZ	4040	4887	1326	4495	4994
		220V/60HZ	4040	4887	4231		4495
		115V/60HZ	4040	4887	4231		4888
4	BAFFLE		-	-	2435	-	
5	DRIER		1717			1096	
6	HIGH PRESSURE SWITCH		334			2683	
7	CONDENSING PRESSURE SWITCH		7476				
8	COIL	220V/50-60HZ	5173				
		115V/60HZ	5414				
9	FILTER		448			30942	
10	HOT GAS VALVE		1473			843	
11	INLET VALVE		335				

WATER CONDENSER



SS/SK

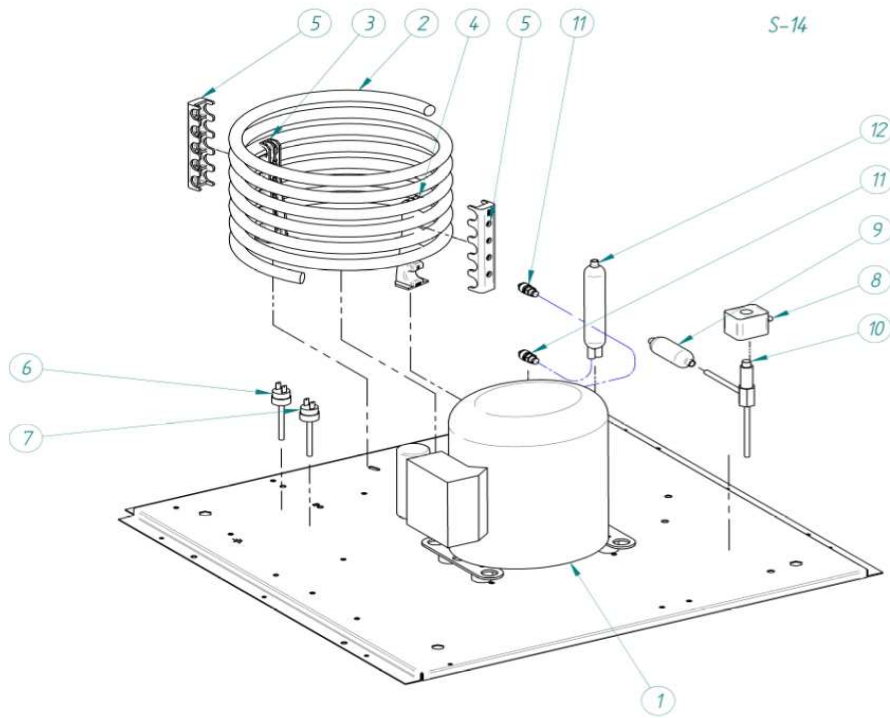

	DESCRIPCION	MODELO				
		35	45	60	80	135
1	COMPRESSOR 220V/50HZ	6005	6515	6007	6763	
2	CONDENSER	5242	5243	5244	5246	
3	WATER CONDENSER UPPER SUPPORT	4036				
4	WATER CONDENSER LOWER SUPPORT	4037				
5	WATER CONDENSER EXTERNAL SUPPORT	4038				
6	HIGH PRESSURE SWITCH	334				2683
7	CONDENSING PRESSURE SWITCH	7476				
8	COIL 220V/50HZ	5173				
9	FILTER	448				
10	HOT GAS VALVE	1473			843	
11	INLET VALVE	335				
12	DRIER	1717				

ELECTRIC BOX



SS/SK

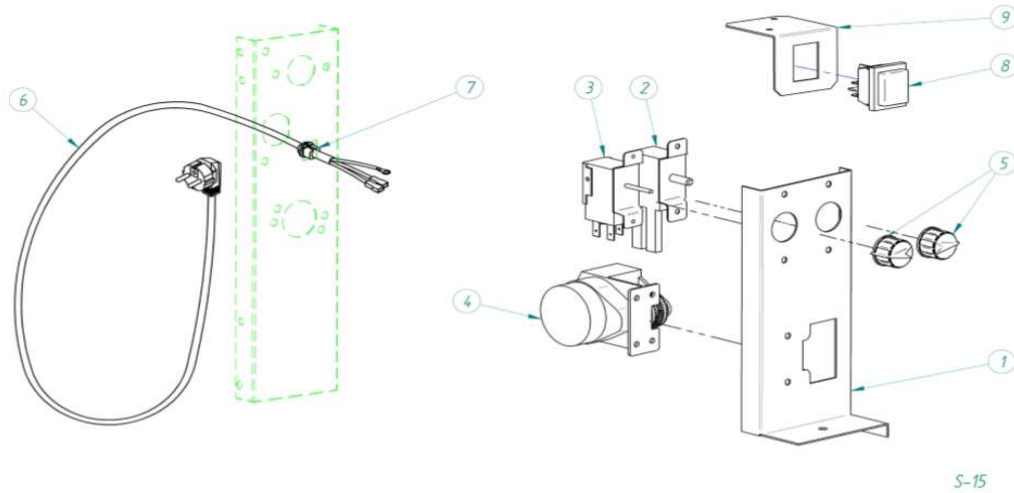

	DESCRIPCION	MODELO					
		35	45	60	80	135	
1	SUPPORT	4469					
2	CYCLE THERMOSTAT	220V/50HZ	153A	4513A	153A	4513A	
		220V/60HZ	153A			4513A	
		115V/60HZ	153A				
3	STOCK THERMOSTAT	274					
4	TIMER	220V/50HZ	380C	4864C	380C	4864C	
		220V/60HZ	380C			4864C	
		115V/60HZ	2764C				
5	THERMOSTAT CONTROL	272					
6	SHUCKO PLUG	220V/50-60HZ	408				
		115V/60HZ	2771				
7	CABLE RETAINER	6536					
	INTERRUPTOR	220V/50HZ	6597				
8		220-115V/60HZ	31679				
9	SOPORTE INTERRUPTOR	4455					