

SS 150

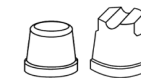

DESPIECE / REPUESTOS
EXPLODED VIEW / SPARE PARTS
EXPLOSIONSZEICHNUNG / ERSATZTEILE
VUE ÉCLATÉE / PIÈCES DÉTACHÉES
ESPLOSO / RICAMBI

CABINET



SS 150

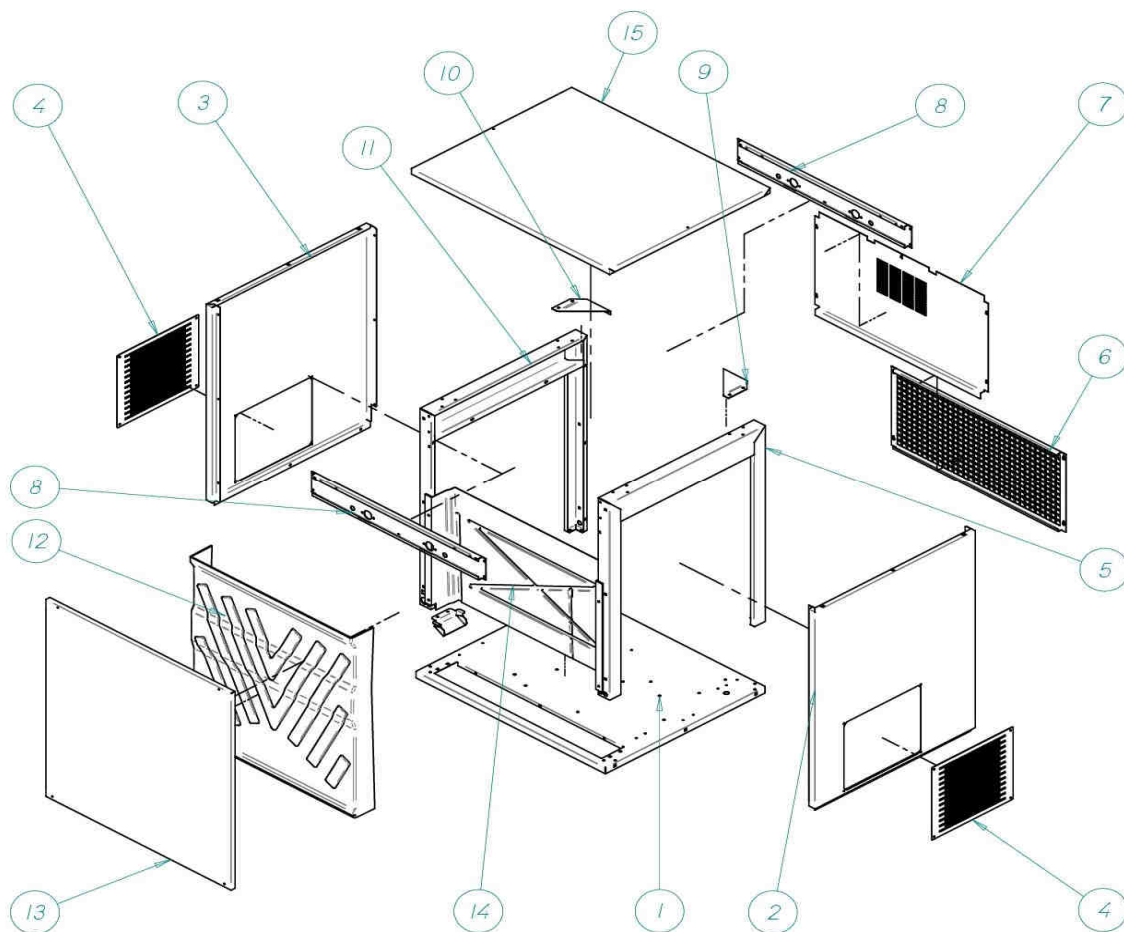

	NAME	
1	BASE	3561
2	RIGHT PANEL	3575
3	LEFT PANEL	3576
4	SIDE GRILL	977
5	RIGHT BRACKET	7363
6	REAR GRILL	3580
7	REAR PANEL	3579
8	UPPER BRACKET	3568
9	RIGHT GUSSET	3565
10	LEFT GUSSET	3566
11	LEFT BRACKET	7363
12	ICE FALL COVER	3570
13	FRONT PANEL	3577
14	INTERIOR ICE FALL	3571
15	TOP COVER	3581

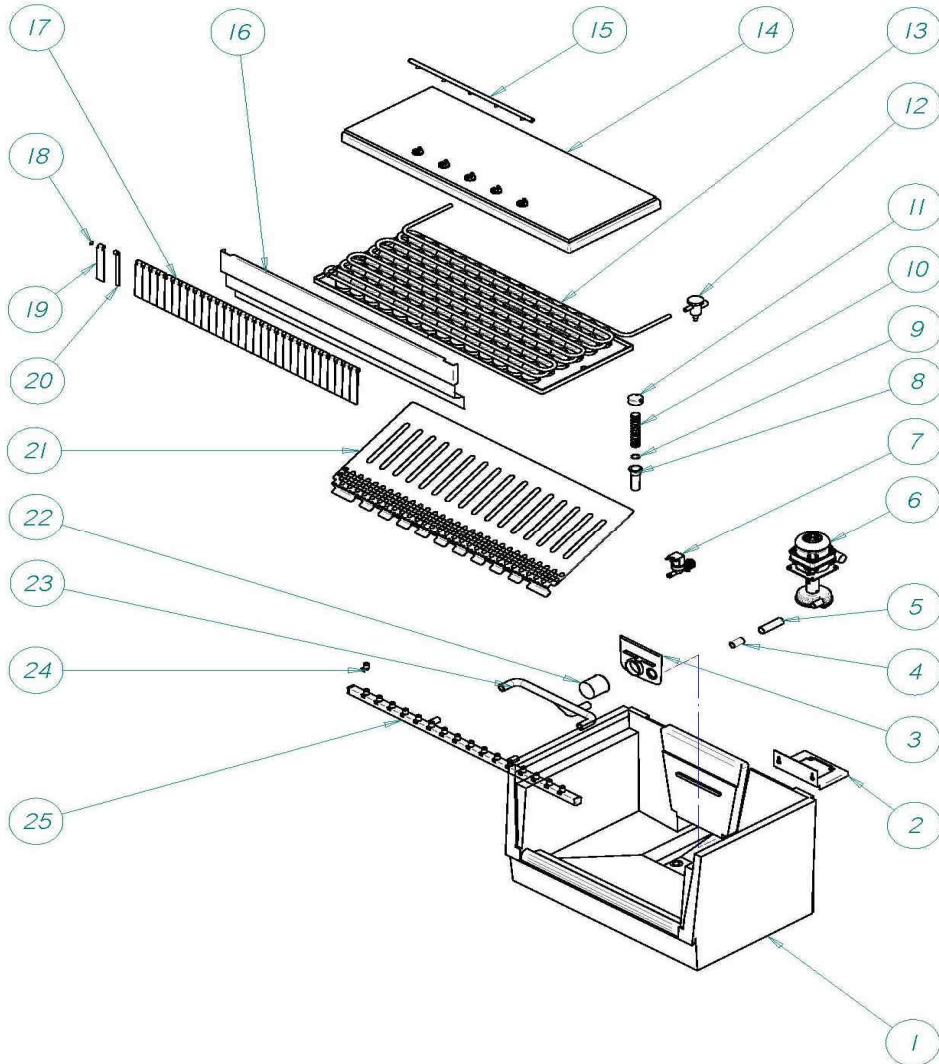

NAME		
1	WATER BIN	7635
2	WATER PUMP SUPPORT	3929
3	FILTER SUPPORT	3924
4	PVC TUBE	6526
5	TUBE	4098
6	WATER PUMP 220V/50-60HZ	5400
7	WATER ELECTROVALVE 220V/50-60HZ	329
8	DRAIN	4425
9	JOINT	4496
10	OVERFLOW DRAIN	4426
11	OVERFLOW PIPE CAP	4427
12	EXPANSION VALVE	1035
13	EVAPORATOR	30 gr. 7379
		40 gr. 7115
		60 gr. 7362
14	EVAPORATOR COVER	5827
15	WATER DISTRIBUTOR	911
16	CURTAIN SUPPORT	3930
17	CURTAIN	5826
18	JOINT	107
19	OUTER CURTAIN FLAP	606
20	INNER CURTAIN FLAP	605
21	CUBE EJECT GRILL	2684
22	FILTER SUPPORT	3941
23	TUBE	2191
24	SPRAY NOZZLE	526
25	COLECTOR	7350

CONDENSER UNIT

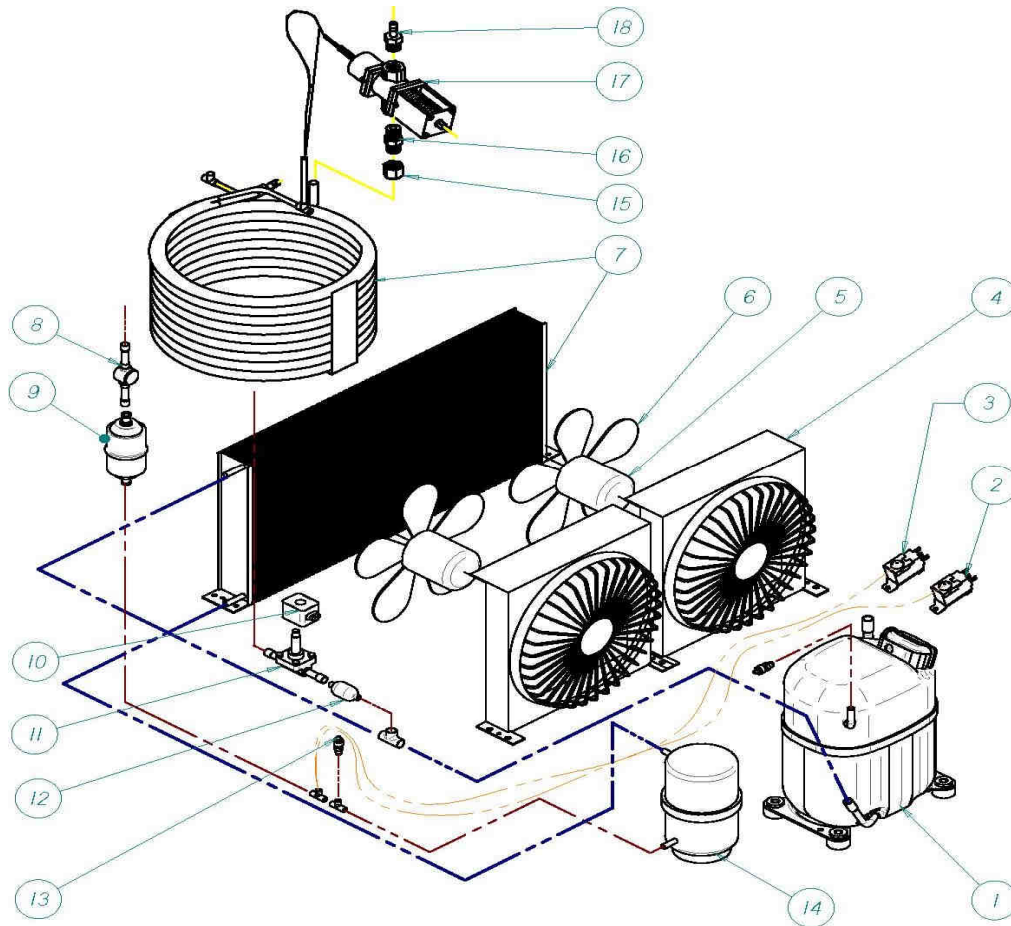

NAME		
1	COMPRESSOR	30441
		220V
		220V/60HZ
2	CONDENS. PRESSURE SWITCH	2507
3	SECURITY PRESSURE SWITCH	2683
4	CONDENSER BAFLE	2435
5	FAN 220V/50-60HZ	4230
6	FAN BLADE	4495
7	AIR CONDENSER	2618
	WATER CONDENSER	3267
8	SIGHT	336
9	DRIER	2560
10	VALV COIL	5173
11	HOT GAS VALVE	843
12	NET FILTER	448A
13	REFRIGER. LOAD VALVE	335
14	LIQUID RECEIVER	6241
15	NUT 3/8"	426
16	UNION 3/8"	430
17	WATER PRESOSTATIC VALVE	425
18	WATER PRESOS. VALV. SPIKE	1015

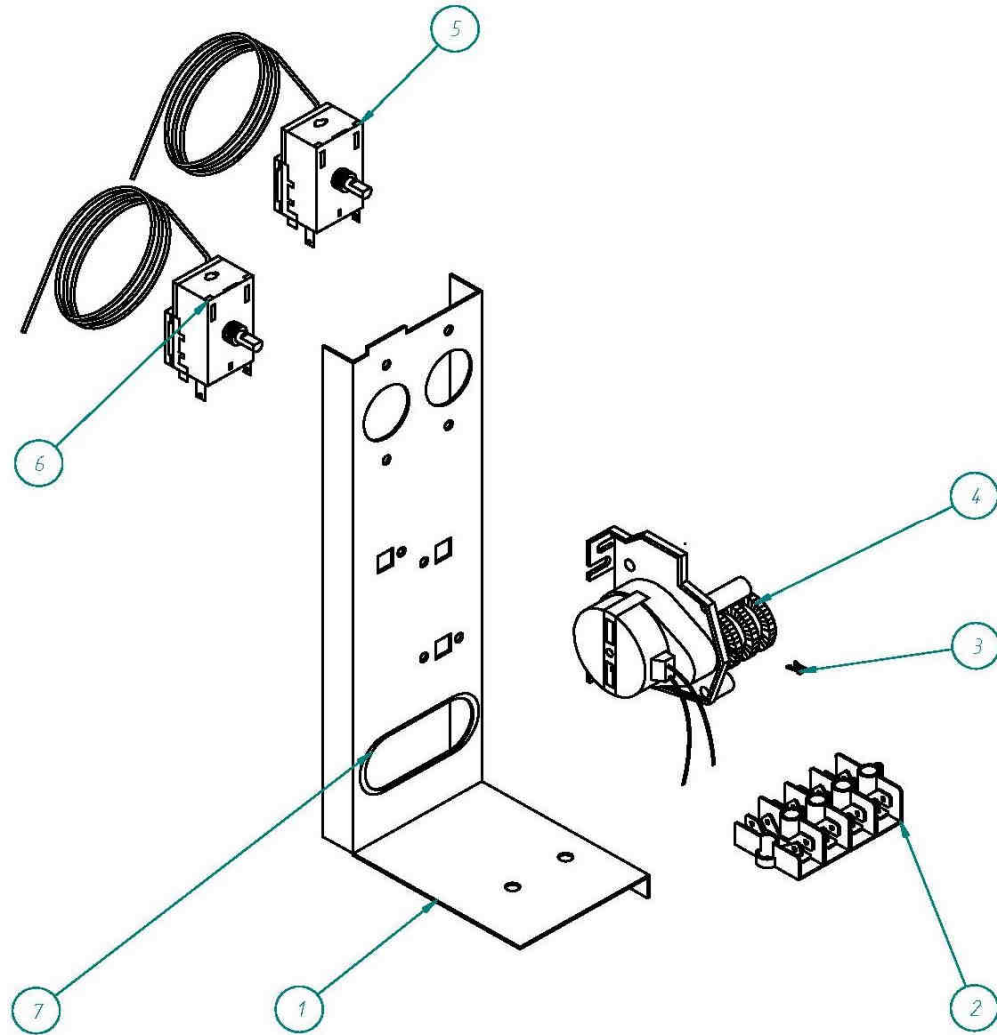

NAME		
1	SUPPORT	2681
2	SEALED SPADE CONNECTOR	5177
3	TAQUET	2756
4	TIMER 20"	380C
5	CYCLE THERMOSTAT	153
6	STOCK THERMOSTAT	274
7	HOLE BUSHING RING	731